

# MASTERPLAT PLUS FRD-PGS MASTERPLAT PLUS LP FRD-PGS MASTERPLAT PLUS TP FRD-PGS

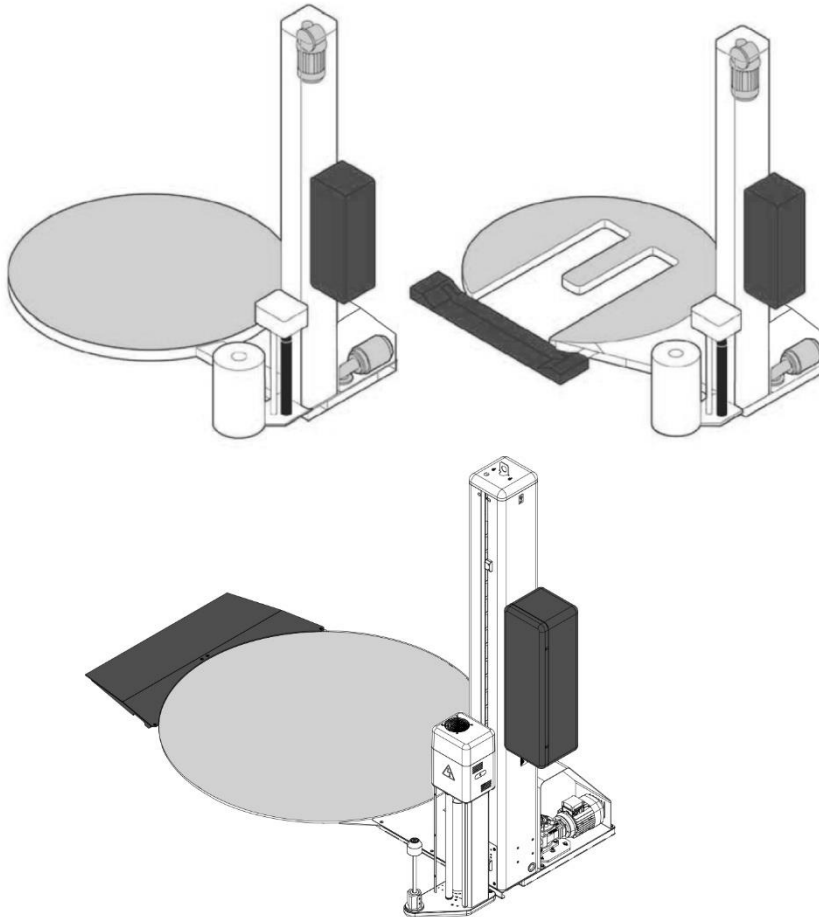

N. matricola • Serial number • Serienummer N. d'identification • Matricula n.	<input type="text"/>
--	----------------------

Cod.: 3709303965	Ed.: 10/2018
------------------	--------------

**ROBOPAC S.p.a**  
Via Fabrizio da Montebello, 81  
47892 Repubblica di San Marino  
Phone (+378) 0549 910511  
Fax (+378) 0549 908549

Page left blank intentionally

## Index

<b>1. GENERAL INFORMATION .....</b>	<b>6</b>
1.1. PURPOSE OF THE MANUAL .....	6
1.2. MANUFACTURER AND MACHINE IDENTIFICATION .....	7
1.3. TERMS AND DEFINITIONS .....	8
1.3.1. PICTOGRAMS INDICATING DANGER .....	9
1.3.2. PICTOGRAMS INDICATING PROHIBITION .....	10
1.3.3. PICTOGRAMS INDICATING OBLIGATION .....	11
1.4. HOW TO REQUEST ASSISTANCE .....	12
1.5. ATTACHED DOCUMENTATION .....	12
1.6. HOW TO READ THE INSTRUCTIONS FOR USE .....	12
<b>2. SAFETY INFORMATION.....</b>	<b>13</b>
2.1. GENERAL SAFETY WARNINGS .....	13
2.2. SAFETY WARNINGS FOR HANDLING AND INSTALLATION .....	14
2.3. SAFETY WARNINGS FOR USE AND OPERATION .....	15
2.4. SAFETY WARNINGS RELATED TO MISUSE .....	16
2.4.1. REASONABLY FORESEEABLE MISUSE .....	16
2.4.2. EMPLOYER OBLIGATIONS .....	16
2.5. SAFETY WARNINGS ON RESIDUAL RISKS .....	17
2.6. SAFETY WARNINGS FOR ADJUSTMENTS AND MAINTENANCE .....	20
2.7. SAFETY WARNING FOR THE ELECTRICAL EQUIPMENT .....	20
2.8. INFORMATION AND SAFETY SIGNS .....	21
2.9. PERIMETER AREAS .....	23
<b>3. TECHNICAL INFORMATION .....</b>	<b>24</b>
3.1. MACHINE GENERAL DESCRIPTION .....	24
3.1.1. MACHINE MODELS DESCRIPTION .....	26
3.2. DESCRIPTION OF THE OPERATION CYCLE .....	27
3.3. SAFETY DEVICE DESCRIPTION .....	28
3.4. DESCRIPTION OF ELECTRICAL DEVICES .....	30
3.4.1. REMOTE CONTROL SOFTWARE .....	32
3.5. DESCRIPTION OF PNEUMATIC DEVICES .....	33
3.6. DESCRIPTION OF ACCESSORIES ON REQUEST .....	34
3.7. "MASTERPLAT PLUS" TECHNICAL DATA .....	38
3.7.1. "MASTERPLAT PLUS FRD" MACHINE AND PALLET DIMENSIONS .....	39
3.7.2. "MASTERPLAT PLUS PGS" MACHINE AND PALLET DIMENSIONS .....	39
3.7.3. "MASTERPLAT PLUS PGS USA" MACHINE AND PALLET DIMENSIONS .....	40
3.7.4. MACHINE TECHNICAL FEATURES .....	40
3.7.5. PRESSER TECHNICAL FEATURES .....	40
3.7.6. "MASTERPLAT PLUS FRD" AND "PGS" SPOOL CHARACTERISTICS .....	41
3.8. "MASTERPLAT PLUS LP FRD" AND "PGS" TECHNICAL DATA .....	42
3.8.1. "MASTERPLAT PLUS LP FRD" MACHINE AND PALLET DIMENSIONS .....	43
3.8.2. "MASTERPLAT PLUS LP PGS" MACHINE AND PALLET DIMENSIONS .....	43
3.8.3. "MASTERPLAT PLUS LP PGS USA" MACHINE AND PALLET DIMENSIONS .....	44
3.8.4. MACHINE TECHNICAL FEATURES .....	44
3.8.5. PRESSER TECHNICAL FEATURES .....	44
3.8.6. "MASTERPLAT PLUS LP FRD" AND "PGS" SPOOL CHARACTERISTICS .....	45
3.9. "MASTERPLAT PLUS TP3 FRD" AND "PGS" TECHNICAL DATA .....	46
3.9.1. "MASTERPLAT PLUS TP3 FRD" MACHINE AND PALLET DIMENSIONS .....	47
3.9.2. "MASTERPLAT PLUS TP3 PGS" MACHINE AND PALLET DIMENSIONS .....	47
3.9.3. MACHINE TECHNICAL FEATURES .....	48
3.9.4. PRESSER TECHNICAL FEATURES .....	48
3.9.5. "MASTERPLAT PLUS TP3 FRD" AND "PGS" SPOOL CHARACTERISTICS .....	49
3.10. NOISE LEVEL .....	50
3.11. INSTALLATION ENVIRONMENT CHARACTERISTICS .....	50
<b>4. INFORMATION ON HANDLING AND INSTALLATION .....</b>	<b>51</b>
4.1. RECOMMENDATIONS FOR HANDLING AND LOADING .....	51
4.2. PACKING AND UNPACKING .....	51
4.3. TRANSPORT AND HANDLING .....	53

4.4. HANDLING AND LIFTING .....	54
4.5. INSTALLATION OF THE MACHINE .....	55
4.5.1. ELECTRIC BOX ASSEMBLY .....	56
4.5.2. SLIDE SHAFT ASSEMBLY .....	57
4.5.3. SLIDE SHAFT ASSEMBLY .....	58
4.5.4. LOADING/UNLOADING RAMP ASSEMBLY .....	59
4.5.4.1. LOADING DIRECTION MODIFICATION .....	60
4.5.5. PNEUMATIC PRESSER ASSEMBLY (OPTIONAL) .....	64
4.6. MACHINE FIXING .....	65
4.7. MACHINE UNDERGROUND INSTALLATION .....	65
4.8. RECOMMENDATIONS FOR CONNECTIONS .....	66
4.9. PNEUMATIC CONNECTION .....	66
4.10. ELECTRICAL CONNECTION .....	67
<b>5. INFORMATION ON ADJUSTMENTS .....</b>	<b>68</b>
5.1. RECOMMENDATIONS FOR ADJUSTMENTS .....	68
5.2. "FILM STRETCH" ADJUSTMENT .....	68
5.2.1. SPOOL CARRIAGES OF "FRD" TYPE .....	68
5.2.2. SPOOL CARRIAGES OF "PGS" TYPE (PRE-STRETCH GEAR REPLACEMENT) .....	69
5.2.3. SPOOL CARRIAGES OF "FRD for mesh" TYPE .....	71
5.3. SPOOL CARRIAGE LIFTING CHAIN ADJUSTMENT .....	72
5.4. ROTARY TABLE CHAIN ADJUSTMENT .....	72
5.5. "TP" ROTARY TABLE CHAIN ADJUSTMENT .....	73
5.6. ADJUSTING ROTARY TABLE GEAR WHEELS .....	74
5.7. ADJUSTING THE TABLE GUIDE WHEELS .....	75
<b>6. INFORMATION ABOUT THE USE .....</b>	<b>76</b>
6.1. RECOMMENDATIONS FOR OPERATION AND USE .....	76
6.2. DESCRIPTION OF THE CONTROLS .....	77
6.3. DESCRIPTION OF USER INTERFACE .....	78
6.4. "MAIN MENU" PAGE .....	79
6.4.1. WRAPPING CYCLE .....	80
6.4.2. TABLE ROTATION SPEED (rpm) .....	81
6.4.3. CARRIAGE SPEED .....	82
6.4.4. WRAPPING END DELAY / PALLET HEIGHT .....	83
6.4.5. MANUAL CONTROLS .....	84
6.4.6. FILM TENSIONING .....	85
6.4.7. OTHER .....	86
6.4.8. SETTINGS .....	87
6.4.9. RECIPE .....	90
6.4.10. MANUAL CYCLE .....	92
6.4.11. ECO CYCLE .....	94
6.4.12. MISCELLANEOUS .....	97
6.5. MACHINE SWITCHING ON AND OFF .....	98
6.6. CYCLE PARAMETERS SETTING .....	98
6.7. DESCRIPTION OF THE WRAPPING CYCLES .....	99
6.7.1. SINGLE WRAPPING CYCLE .....	99
6.7.2. DOUBLE WRAPPING CYCLE .....	99
6.7.3. WRAPPING CYCLE WITH FEEDER .....	100
6.8. CYCLE START AND STOP .....	101
6.8.1. INFORMATION VALID ONLY FOR "FEEDER CYCLE" WRAPPING MODE .....	101
6.9. PRESSER HEIGHT CHANGE .....	102
6.10. PNEUMATIC CYLINDER WITH ROD .....	102
6.11. SPOOL LOADING .....	103
<b>7. MAINTENANCE INFORMATION .....</b>	<b>105</b>
7.1. RECOMMENDATIONS FOR MAINTENANCE .....	105
7.2. PERIODICAL MAINTENANCE INTERVALS .....	106
7.3. LUBRICATION POINT DIAGRAM .....	108
7.4. LUBRICANT TABLE .....	110
7.5. CONDENSATE DRAINAGE .....	111

7.6. AIR FILTER CLEANING .....	111
7.7. MACHINE CLEANING .....	112
<b>8. FAULT INFORMATION .....</b>	<b>113</b>
8.1. ALARM MESSAGES .....	113
<b>9. REPLACEMENT INFORMATION .....</b>	<b>114</b>
9.1. RECOMMENDATIONS FOR REPLACING MACHINE PARTS .....	114
9.2. REPLACING THE ROTARY TABLE WHEELS .....	115
9.3. REPLACING THE ROTARY TABLE ROLLERS .....	116
9.4. REPLACING THE GUIDING ROLLERS .....	117
9.5. REPLACING THE ROTARY TABLE GEAR WHEELS .....	118
9.6. RECOMMENDED SPARE PARTS LIST .....	119
9.7. MACHINE DECOMMISSIONING AND SCRAPPING .....	120
9.7.1. MACHINE DECOMMISSIONING .....	120
9.7.2. MACHINE SCRAPPING .....	120
<b>10. ANNEXES .....</b>	<b>121</b>
10.1. WARRANTY CONDITIONS .....	121
10.2. PRESSER PNEUMATIC DIAGRAM .....	122

## 1. GENERAL INFORMATION

### 1.1. PURPOSE OF THE MANUAL

- The manual is an integral part of the machine and is aimed at providing the operator with the “Instructions for use” in order to prevent and minimise the risks that arise from human-machine interaction.  
**The information has been written by the Manufacturer in Italian (the original language) in full compliance with the professional writing principles and the regulations in force.**  
**The communication principles were chosen according to the target readers in order to ease the reading and understanding of the information.**  
**The information may be translated into other languages to satisfy the legal and/or market requirements.**  
**The manuals must be translated directly from the original instructions, without modifications.**  
**Each translation (including that provided by the purchasing agent or by the company that introduces the machine into the country in question) must specify the message “Translation of the original instructions”.**
- Refer to the table of contents in order to easily identify the subjects of interest.
- Some information may not correspond completely to the actual configuration of the machine delivered.
- Any additional information does not affect the readability of the text and the safety level.
- The Manufacturer reserves the right to modify the contents of the manual without prior notice provided that the safety level is not altered.
- Every notification by the recipients can be an important contribution to the improvement of after-sales services that the manufacturer intends to offer to its customers.
- The symbols described below are used to highlight important information or specifications.



#### **Danger - warning**

The symbol indicates critically dangerous situations that if neglected can result in serious personal safety and health hazards.



#### **Caution - warning**

The symbol indicates that suitable actions must be taken in order to avoid personal safety and health hazards and economic damages.



#### **Important**

The symbol indicates particularly important technical and operating information that should not be neglected.

## 1.2. MANUFACTURER AND MACHINE IDENTIFICATION

The illustrated identification plate is applied directly to the machine. It contains references and indispensable operating safety indications.

- 1) Machine model.
- 2) Machine serial number.
- 3) Year of manufacture.
- 4) Power supply voltage.
- 5) Power supply frequency.
- 6) Power supply phases.
- 7) Absorbed electric current.
- 8) Installed power.
- 9) Air consumption.
- 10) Air supply max. pressure.
- 11) Machine weight.
- 12) Manufacturer's identification.
- 13) Name.

12

ROBOPAC

**ROBOPAC S.p.a**  
**Via Fabrizio da Montebello, 81**  
**47892 Repubblica di San Marino**  
**Phone (+378) 0549 910511**  
**Fax (+378) 0549 908549**

CE

DENOMINAZIONE DENOMINATION	13	
MODELLO MODEL	1	
MATRICOLA SERIAL NUMBER	2	
DATA DATE OF MAN.	3	
ALIMENTAZIONE SUPPLY VOL.	4	V
FREQUENZA FREQUENCY	5	Hz
N.FASI PHASE	6	
ASSORBIMENTO ABSORPTION	7	A
POTENZA TOT. TOTAL POWER	8	kw
CONSUMO ARIA AIR CONSUMPTION	9	l/min
PRESSIONE MAX MAX. PRESSURE	10	bar
PESO WEIGHT	11	kg

### 1.3. TERMS AND DEFINITIONS

Some recurring terms found within the manual are described in order to complete their meaning.



**Maintenance:**

The set of operations required to maintain the machine efficient and in good working order. Normally some operations are scheduled by the manufacturer, who defines the necessary skills and methods of intervention.  
Some unscheduled operations must be performed after consulting the manufacturer.



**Operator:**

A person chosen and authorised among those who have the requirements, skills and information necessary for installation, use and ordinary maintenance of the machine.



**Maintenance technician:**

Technician chosen and authorised among those who have the requirements to perform routine and extraordinary maintenance on the machine. Therefore, the technician must have accurate information and competences with particular skills in the field of intervention.



**Format changeover:**

Set of operations to carry out on the machine before starting to work with characteristics other than the previous ones.



**Training:**

Training process aimed at transferring to the new operator the knowledge, skills and behaviours required to operate the machine autonomously, properly and safely.



**Installer:**

Technician chosen and authorised by the manufacturer or by its representative, among those with the requirements to install and test the machine or the relevant system.



**Assistant:**

Employee assigned to assist the production processes of the machine or system in question.



**Production manager:**

Qualified technician, with experience and competence in the field of machinery for the reference sector.  
Depending on the production requirements, the production manager can operate the machine directly, or select the operator to be assigned to the task.



### 1.3.1. PICTOGRAMS INDICATING DANGER

The following table summarises the safety-related pictograms which indicate **DANGER**.



**ATTENTION - GENERIC DANGER**

This draws the attention of the personnel concerned to the risk of physical injuries caused by the operation described if it is not carried out in compliance with safety regulations.



**ATTENTION - DANGER DUE TO CONTACT WITH LIVE PARTS**

This indicates to the personnel concerned that the described operation poses, if not carried out in compliance with safety regulations, a risk of electric shock.



**ATTENTION - DANGER DUE TO FLAMMABLE MATERIAL**



**ATTENTION - DANGER DUE TO MOVING PARTS**



**ATTENTION- DANGER DUE TO HIGH TEMPERATURES**



**ATTENTION - DANGER DUE TO SUSPENDED LOADS**



**ATTENTION - DANGER DUE TO CONTACT WITH OVERHEAD OBSTACLES**



**ATTENTION - TRIPPING OR FALLING DANGER**



**ATTENTION - TANGLING DANGER**

It signals to the concerned personnel that the device bearing this pictogram features parts where there is the risk getting tangled when accessed.



**ATTENTION - HAND CRUSHING DANGER**



**ATTENTION - SHEARING DANGER**



**ATTENTION - CUTTING DANGER**

It signals to the concerned personnel that the device on which the pictogram is located has sharp parts that may injure their hands.



**ATTENTION - DANGER DUE TO CARRIAGE MOVEMENT**



**ATTENTION - EXPLOSION DANGER**

### 1.3.2. PICTOGRAMS INDICATING PROHIBITION

The following table summarises the safety-related pictograms indicating **PROHIBITION**.



**GENERIC PROHIBITION**



**NO SMOKING**

Smoking is not allowed in the area where this sign is located.



**NO NAKED FLAMES**

This symbol prohibits the use of naked flames near the machine or parts of it to prevent a fire hazard.



**NO PEDESTRIANS**

Pedestrians are not allowed to pass through the area where this signal is located.



**DO NOT EXTINGUISH WITH WATER**

Any fire that may occur near the machine or parts of it must **NOT** be extinguished with jets of water.



**DO NOT INSERT YOUR HANDS**



**DO NOT PUSH**



**DO NOT SEAT DOWN**



**DO NOT CLIMB ONTO THE SURFACE**



**DO NOT REMOVE THE OPERATOR GUARDS**

### 1.3.3. PICTOGRAMS INDICATING OBLIGATION

The following table summarises the safety-related pictograms indicating **OBLIGATION**.



#### **GENERIC OBLIGATION**

The presence of the symbol next to the description indicates the obligation to carry out the operation/manoeuvre as described and in compliance with current safety regulations, in order to avoid risks and/or injuries.



#### **OBLIGATION TO REFER TO THE OPERATOR'S MANUAL**

Obligation, before carrying out any operation on the machine, to read the Instruction Manual supplied with the machine.



#### **OBLIGATION TO USE LUBRICANTS RECOMMENDED BY IMA**

Obligation, before changing the oil or the lubricants, to read the Instruction Manual supplied with the machine.



#### **OBLIGATION TO WEAR PROTECTIVE GLOVES**

The presence of the symbol next to the description requires the use of protective gloves by the operator, since the risk of injury is implicit.



#### **OBLIGATION TO WEAR PROTECTIVE GOGGLES**

The presence of the symbol next to the description requires the use of safety goggles by the operator, since the risk of injury is implicit.



#### **OBLIGATION TO WEAR A PROTECTIVE HELMET**

The presence of the symbol next to the description requires the use of a protective helmet by the operator since the risk of injury is implicit.



#### **OBLIGATION TO WEAR A PROTECTIVE MASK**

The presence of the symbol next to the description requires the use of a respiratory protective mask by the operator, since the risk of injury is implicit.



#### **OBLIGATION TO WEAR SAFETY SHOES**

The presence of the symbol next to the description requires the use of protective shoes by the operator, since the risk of injury is implicit.



#### **OBLIGATION TO WEAR PROTECTIVE CLOTHING**

The presence of the symbol next to the description requires the use of a protective overall by the operator, since the risk of injury is implicit.



#### **OBLIGATION TO WEAR EARMUFFS FOR PROTECTION AGAINST NOISE**

The presence of the symbol next to the description requires the use of earmuffs by the operator as the risk of injury is implicit.

#### 1.4. HOW TO REQUEST ASSISTANCE

**Robopac** distribution network is at your disposal for any problem regarding technical assistance, spare parts and any new requirement you might need for your business.

For every technical service request regarding the machine, please indicate the data found on the identification plate, the approximate hours of use and the type of fault detected.

Please refer to one of the authorised service centres or directly to the address indicated for any need.

ROBOPAC S.p.A  
VIA FABRIZIO DA MONTEBELLO, 81  
47892 GUALDICCILO REPUBLIC OF S. MARINO (RSM)  
Tel. 0549 (international ++378) 910511  
Fax 0549/908549 - 905946  
<http://www.aetnagroup.com>

#### 1.5. ATTACHED DOCUMENTATION

The machine is provided with the documentation listed below, unless otherwise agreed.

- EC DECLARATION OF CONFORMITY.
- Warranty conditions.
- Pneumatic diagram.
- Wiring diagram and list of components.
- Manuals of installed commercial devices (if necessary for machine use).
- Unpacking and installation instructions.
- Quick guide for quick start.
- USB pendrive containing the information listed below.
  - Use and maintenance manual translated into various languages.
  - Spare parts catalogue.
  - Machine programming software.
  - Wiring Diagrams.

#### 1.6. HOW TO READ THE INSTRUCTIONS FOR USE

The manual is divided into chapters, each of which describes a specific category of information.



**Important**

**Every operator who interacts with the machine, in addition to reading all the documentation, must read and learn the information that falls within his/her operational competence.**

Refer to the abbreviation that precedes the title of the chapters in the index, to search for topics to consult.

These instructions are the result of an automatic system that assembles text and illustrations, so it is possible that when changing pages, there might be interruptions in the flow of text and tables.



**Important**

**Keep this manual for the entire duration of the machine useful life in a well known and easy to access place, available for reference any time the need should arise.**

## 2. SAFETY INFORMATION

### 2.1. GENERAL SAFETY WARNINGS



#### **Caution - warning**

Carefully read the “Instructions for use” specified in the manual and those applied directly to the machine.

It is important to dedicate a little time to read the “Instructions for use” in order to minimise the risks and avoid unpleasant accidents.

Before performing any operation, the operator must make sure that he/she has understood the “instructions for use”.



#### **Danger - warning**

Pay attention to the safety warnings, do not misuse the machine and assess the possible residual risks.

Caution is essential.

Safety is also in the hands of those who interface with the machine throughout its life span.



#### **Important**

**Sometimes, accidents can be caused by a “careless” use of the machine by the operator.**

**Usually it is too late to remember what should have been done when the accident has already happened.**



#### **Caution - warning**

Preserve the readability of the information signs and observe the indications given.

The information signs may have different shapes and colours, indicating hazards, obligations, prohibitions and indications.

Tampering with the safety devices and the removal of the same may create risks (even severe) for the operators.

The personnel authorised to carry out any operation with the machine must have acknowledged experiences in the specific field.



#### **Important**

**The manufacturer is not responsible for any damage to the packaged product occurred during wrapping, stabilisation and following operations.**



#### **Important**

**Non-compliance with the instructions given may cause risks to the safety and health of people, as well as economic damages.**

## 2.2. SAFETY WARNINGS FOR HANDLING AND INSTALLATION



### **Danger - warning**

The personnel authorised to handle the machine (load and unload) must possess the necessary technical and professional knowledge and skills.

Handle (load and unload) the machine according to the instructions affixed directly to the machine, to the package and in the user manual.

During handling use one or more assistants, if required. This may pose unexpected risks.

In order to minimise the risks related to assistants' involvement, you must inform them in advance on the type of work to be carried out and the behaviour to adopt.

Handling must be carried out with the aid of specific means (crane, forklift truck etc.) by qualified personnel capable of observing the safety requirements.

When using the lifting means, insert and/or fasten the devices (hooks, forks etc.) only into the points provided on the package and/or on the machine.

Transport the machine with suitable means of adequate capacity.

The minimum and maximum temperature (during transport and/or storage) must fall within the range allowed in order to prevent damaging the electrical components.

Install the machine only in spaces with no explosion and/or fire risks.

Avoid spaces exposed to atmospheric and corrosive agents.

Assess, prior to installation, if it is necessary to implement a "safety plan" in order to protect the safety of the personnel involved.

Provide proper safety conditions when operating in high areas that are dangerous or hard to access.

Install the machine according to the minimum perimeter spaces indicated by the Manufacturer and the surrounding working activities.

Prepare a machine installation project if the machine is to interact (directly or indirectly) with another machine or with a production line.

The project must take into account all operating conditions, in order to comply with all laws in force on matter of safety in the workplace.

Check that the installation space is properly ventilated in order to avoid unhealthy air concentration for the operators.

Implement the most suitable solutions to minimise noise emission levels and acoustic pollution.

Carry out the electrical connections in accordance with the best practice and in full compliance with the instructions provided by the Manufacturer and the specific regulations in force.



### **Important**

**The electrical connections must be carried out exclusively by operators with acquired and acknowledged skills in the field of intervention.**

The installer must test the machine and check, through a general test, that the machine can be commissioned without any risk for the operator.

Dispose of all the packaging components in compliance with the standards in force in the Country of installation.

**Non-compliance with the instructions given may cause risks to the safety and health of people, as well as economic damages.**

## 2.3. SAFETY WARNINGS FOR USE AND OPERATION



### **Danger - warning**

The operator must be trained and possess the adequate skills required to carry out the specific tasks and must be fit to use the machine safely.

When using the machine for the first time, the operator must read the manual and identify the control functions and simulate some operations, especially machine start and stop.

The machine has been designed and manufactured to meet all the operating conditions indicated by the Manufacturer.



### **Caution - warning**

Use the machine only with the original safety devices installed by the Manufacturer.  
Do not tamper with, disable, remove or bypass the safety devices installed on the machine.



### **Danger - warning**

Do not modify the constructive and functional characteristics of the machine in any way.

Do not use the machine with the safety devices not properly installed and efficient.

Always wear the Personal Protective Equipment indicated in the "Instructions for use", **in particular safety shoes**, and that provided for by the laws in force on matter of safety in the workplace.

Always keep the perimeter areas in suitable conditions and free from obstacles in order to minimise the risks for the operator, especially near the control station.

The machine must be used **by one operator only**, that must be appointed and authorised by the employer.

The involvement of one or more assistants when performing some operations or maintenance (ordinary) interventions may pose unpredictable risks.

In order to minimise the risks related to assistants' involvement, you must inform them in advance on the type of work to be carried out and the behaviour to adopt.

Make sure that no unauthorised persons are within the machine operating area during its production activity and during maintenance.

It is forbidden to climb onto the rotary table with forklift trucks. In addition to being dangerous, it can also damage the machine.



### **Important**

**Non-compliance with the instructions given may cause risks to the safety and health of people, as well as economic damages.**

## 2.4. SAFETY WARNINGS RELATED TO MISUSE

### 2.4.1. REASONABLY FORESEEABLE MISUSE

- The reasonably foreseeable misuse is: “the use of the machine in a way other than that indicated in the manual, that may stem from the easily predictable human behaviour”.  
**The machine must be used only for wrapping and stabilising products with regular shape or with a shape that ensures a stable wrapping.**  
**Packages containing liquids or insubstantial materials must have characteristics suitable to the product and be perfectly closed and sealed to prevent the contents from flowing out.**  
 Do not palletize or wrap products housed in irregularly shaped packages (boxes, liquid containers, etc.) or packages that do not guarantee their stability.
- The machine should only be used for the uses intended by the Manufacturer.
- Do not allow the machine to be used by operators that are not properly trained, informed and authorised.
- Packages containing liquid or insubstantial products must ensure that they do not leak out.
- Do not wrap bulk products of irregular shape and improperly collected to avoid an unsuitable palletization.
- Do not use the machine to wrap and stabilise living beings (animals and persons).
- Do not use the machine with wrapping material other than that provided by the Manufacturer.
- Do not use the machine as a lifting device or as a work surface (e.g. workbench).
- Do not stretch or pre-stretch the film excessively and do not wrap the product with too many wrappings in order to prevent damaging the packages and the products contained in them.
- Do not use or let the machine be used for purposes or in ways other than those intended by the Manufacturer.
- Do not use or let the machine be used with defective, deactivated and/or incorrectly installed safety devices.
- Do not continue to use the machine if malfunctions have been detected.
- Stop the machine immediately and restart it only after the normal conditions of use have been restored.
- Never carry out an intervention with the machine in operation, but only after stopping it properly, under safety conditions.
- Never use the machine without wearing the Personal Protective Equipment indicated by the Manufacturer and provided for by the laws in force on workplaces.
- Never use the machine if the scheduled maintenance interventions have not been carried out.
- Do not clean or wash the machine with aggressive products to avoid damaging the components.
- Do not replace the components with non-original spare parts or part with different design and construction features.
- Do not leave the machine unattended at the end of the production activity without shutting it down first in safety conditions.

### 2.4.2. EMPLOYER OBLIGATIONS

- The operator must be trained to acquire the required skills in the field of packaging machines or equivalent. Upon completing the training, ensure that the operator has understood the entire content of the operating manual, in particular the safety information.
- The operator must have the required skills and must be fit for the activities to be carried out in safety conditions.
- The employer must inform the operator on the reasonably foreseeable misuses and on the persistent residual risks.
- The operator must be capable of reading and understanding the user manual and must easily identify the safety signs.
- Allow the machine to be used only by operators that are properly trained, informed and authorised.



#### **Important**

**The employer must document the training carried out for the operators.**



## 2.5. SAFETY WARNINGS ON RESIDUAL RISKS



### Danger - warning

During design and manufacturing, the Manufacturer has paid particular attention to the residual risks that may affect the safety and health of the operators.

The residual risks are: "all the risks that persists although all safety solutions have been applied and integrated during machine design".

The list specifies the residual risks specific for this type of machine.



### Risk of slipping:

Do not climb on machine parts during its operation.

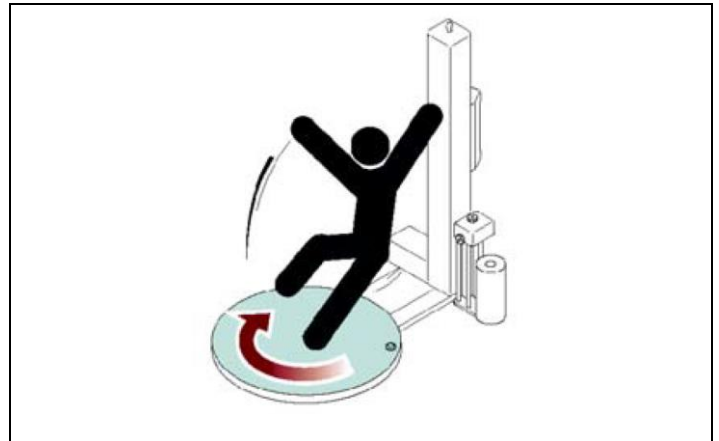

### Risk of impact:

Do not approach machine parts during its operation.

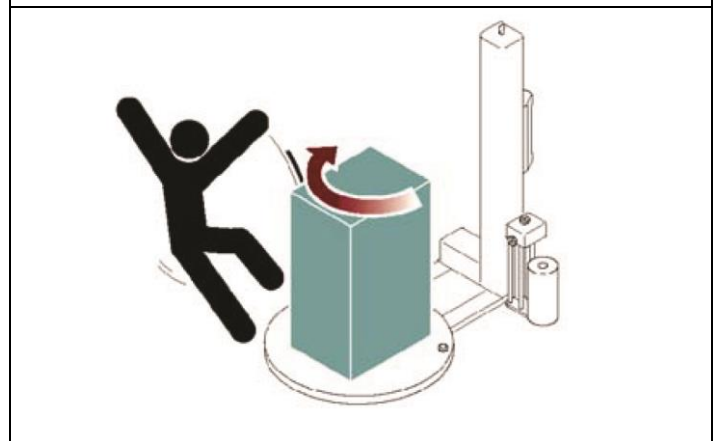

### Risk of shearing upper limbs:

Do not insert your hands inside moving parts.

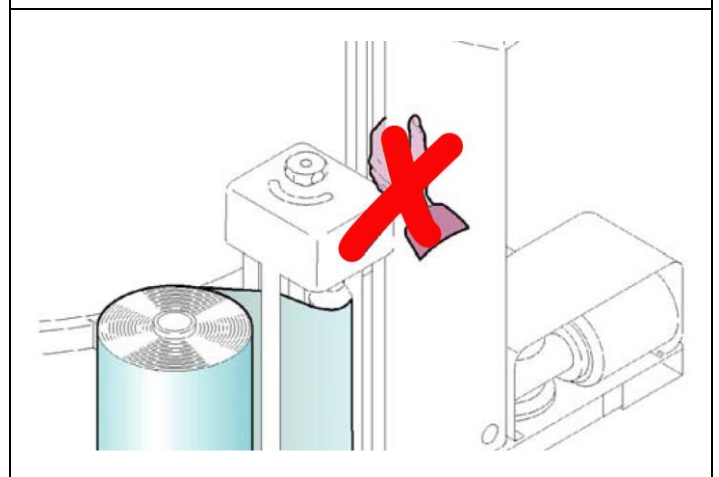



**Risk of body crushing:**  
Do not stand in the machine operating area.

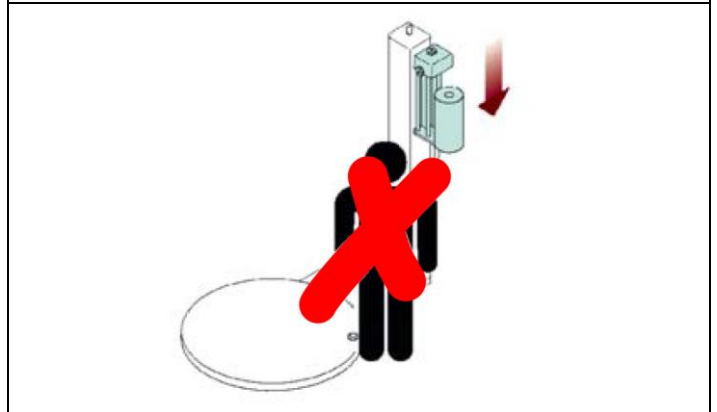
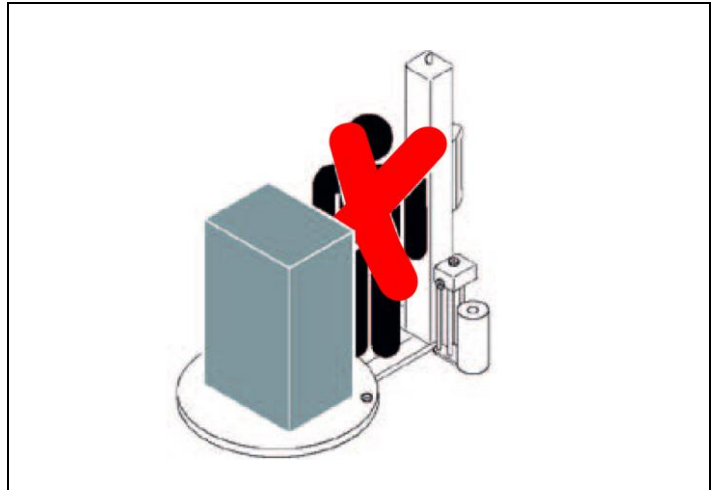

**Risk of crushing upper limbs:**  
Do not insert your hands inside moving parts.

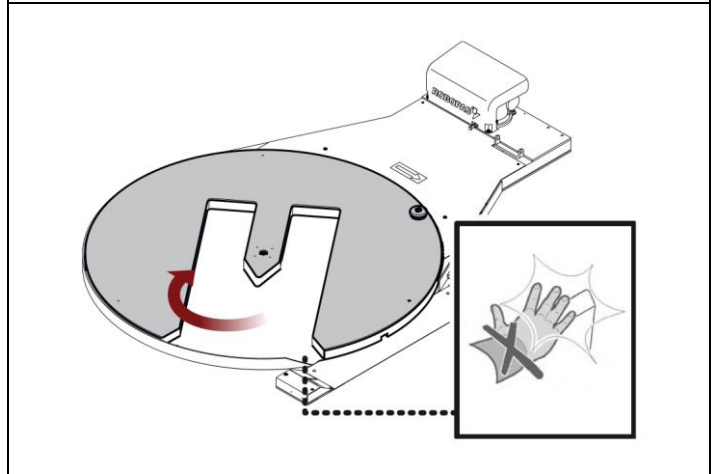



**Risk of impact and slipping:**

Do not approach or climb on machine parts (e.g.: rotary table) with the lifting device during machine operation.



**Risk of falling or ejected objects:**

Do not use the machine at a speed which is not suitable for the type of product to be wrapped.



If the packages to be wrapped contain unstable and dangerous elements, it is necessary to implement appropriate safety measures (e.g.: perimeter protections) to avoid risks of injuries to persons.

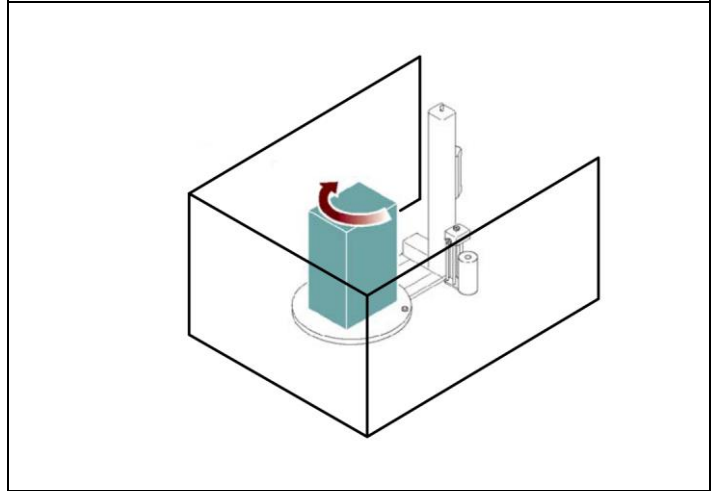

## 2.6. SAFETY WARNINGS FOR ADJUSTMENTS AND MAINTENANCE

- Keep the machine in maximum efficiency conditions and perform all the scheduled maintenance operations provided for by the Manufacturer.  
Proper maintenance will provide the best performance, a longer life span and constant compliance with safety requirements.
- Enable all machine safety devices before performing any maintenance and adjustment operations.
- Demarcate the surrounding areas and put in place adequate safety measures, as provided for by the standards on workplace safety, in order to prevent and minimise the risks.
- Maintenance interventions in areas that are not easily accessible or dangerous must be carried out after having ensured the necessary conditions are met.
- The personnel authorised to carry out the ordinary maintenance (adjustments, replacements etc.) must possess the necessary technical and professional knowledge and skills.
- Do not carry out interventions other than those indicated in the user manual without the express authorisation of the Manufacturer.
- Do not use products that contain corrosive and flammable substances or that are harmful to people's health.
- Wear Personal Protective Equipment as required by labour laws and as indicated in the "Instructions for Use" and/or on the machine.
- The use of similar but non-original spare parts may result in improper repairs, altered performance and economic damage.
- Use lubricants (oils or grease) recommended by the Manufacturer or with similar chemical-physical features.
- Do not dispose of polluting liquids, worn parts and maintenance waste into the environment.
- Select the components according to the chemical and physical features of the material and dispose of them separately in accordance with the applicable laws.
- All the extraordinary maintenance interventions shall be carried out only by authorised personnel with experience and expertise in the field of intervention.



### Important

**Non-compliance with the instructions given may cause risks to the safety and health of people, as well as economic damages.**

## 2.7. SAFETY WARNING FOR THE ELECTRICAL EQUIPMENT

The electrical equipment has been designed and manufactured in accordance with the relevant standards. These standards consider operating conditions based on the surrounding environment.

The list contains the conditions necessary for the correct operation of the electrical equipment.

- Ambient temperature must be within **5°C** and **40°C**.
- The relative humidity should be between **50%** (measured at **40°C**) and **90%** (measured at **20°C**).
- The installation environment must be immune to and must not be a source of electromagnetic interference or radiation (x-rays, lasers, etc.).
- The environment must not have areas with concentrations of gas and dust that are potentially explosive and/or with a fire risk.
- The products and materials used during production and maintenance must not contain contaminants or corrosive agents (acids, chemicals, salts, etc.) and must not be able to penetrate and/or come into contact with electrical components.
- During transport and storage, the ambient temperature must be between **-25°C** and **55°C**.
- The electrical equipment may still be exposed to a temperature of up to **70°C** provided that the exposure time does not exceed **24** hours.
- The electrical equipment operates correctly up to **1000 m** above sea level.



### Important

**If it is not possible to comply with one or more of the conditions listed, which are essential for the correct operation of the electrical equipment, it is necessary to agree at the contractual stage which additional solutions to adopt in order to create the most suitable conditions (e.g. specific electrical components, air conditioning equipment, etc.).**

## 2.8. INFORMATION AND SAFETY SIGNS

The figure indicates the position of the safety and information signs affixed to the machine. For each sign the relative description is specified.

1. **Electrical hazard sign**  
Do not access the area to avoid risks of electric shock or electrocution.
2. **Prohibition sign**  
Do not climb on the ramp with the forklift truck.
3. **Information sign**  
It indicates the lifting points with hook device.
4. **Information sign**  
It indicates the lifting points with fork device.
5. **Information sign**  
It indicates the rotary table rotation direction.
6. **Prohibition sign**  
Do not act on the component with your hands.
7. **Danger sign**  
Hand crushing danger.



### **Important**

Make sure that the nameplates are clearly legible.  
If not, replace and reposition them at the original position.

**Masterplat PLUS**

**Masterplat PLUS TP3**

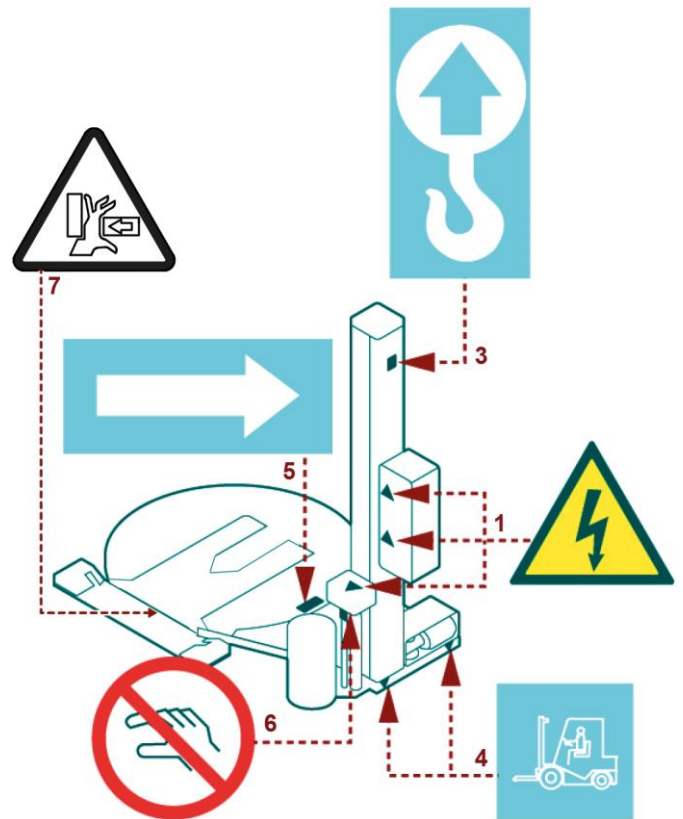
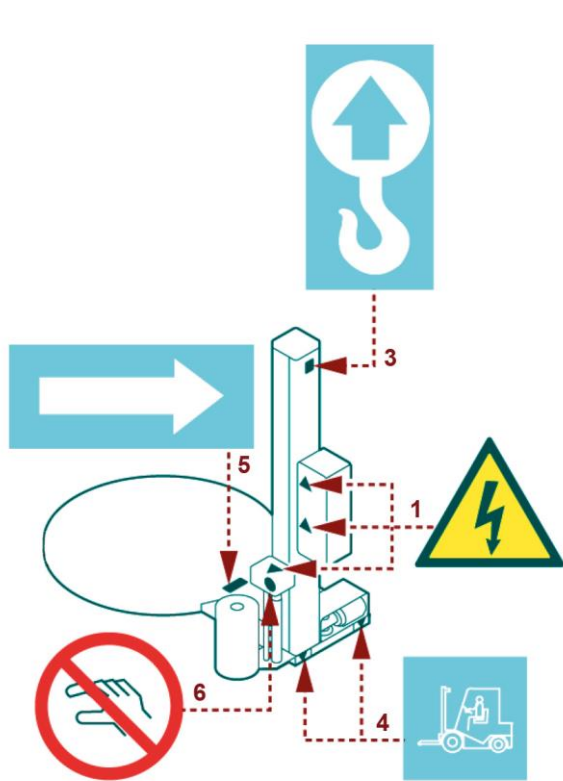

**Masterplat PLUS LP**

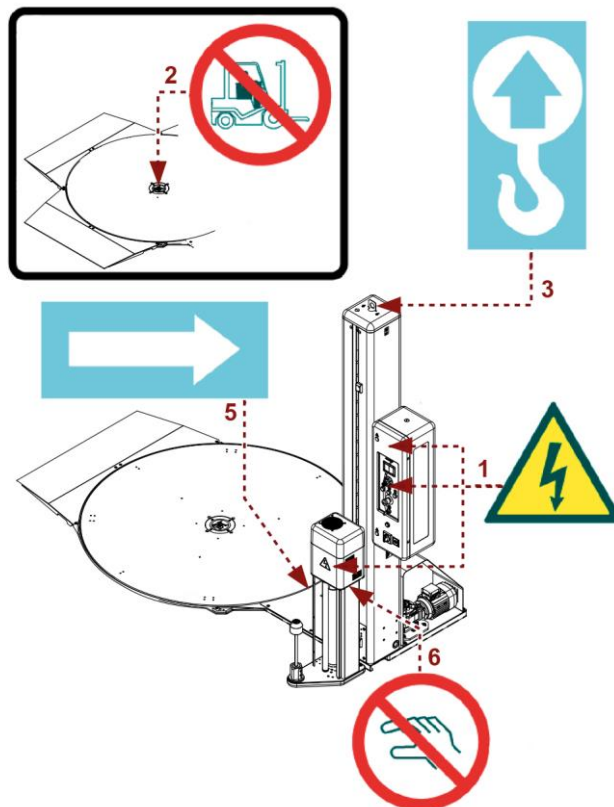

## 2.9. PERIMETER AREAS

The illustration shows the perimeter working areas of the machine.

1. Operator standing area.
2. Pallet loading/unloading area.
3. Perimeter area.

### Masterplat PLUS

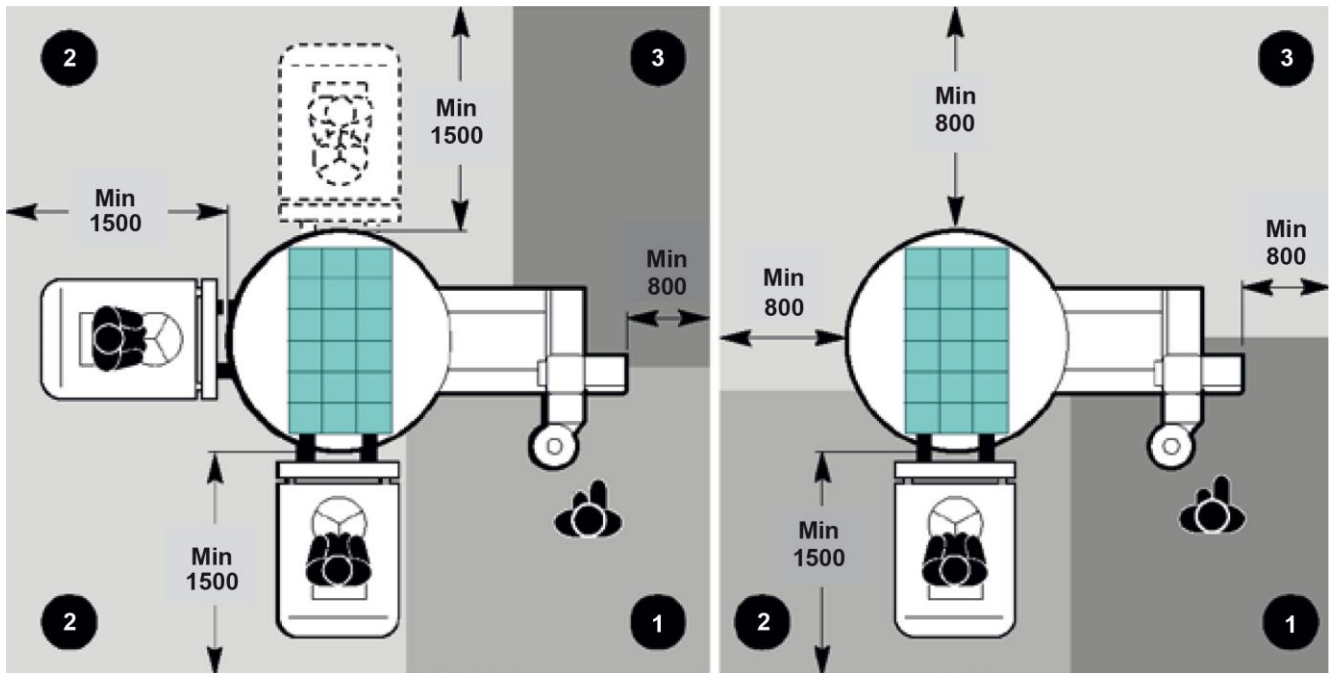

### Masterplat PLUS TP3

### Masterplat PLUS LP

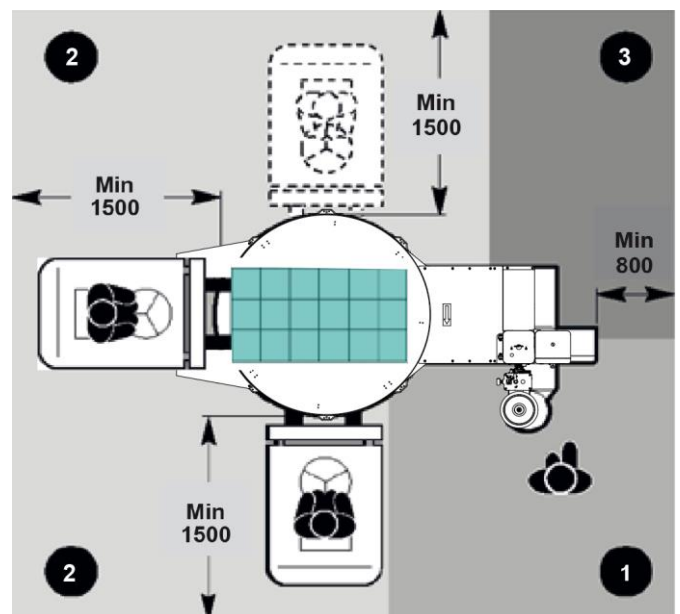
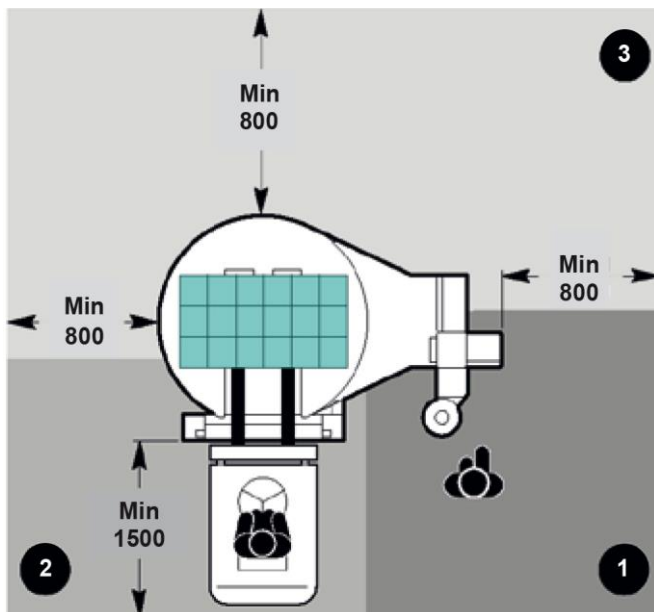

### 3. TECHNICAL INFORMATION

#### 3.1. MACHINE GENERAL DESCRIPTION

- The machine is a semi-automatic machine for palletised load wrapping and stabilising with stretch film.
- The machine must be used only for wrapping and stabilising products contained in packages (in boxes, liquid containers, etc.) with regular shape or with a shape that ensures a stable palletisation.
- Packages containing liquids or insubstantial materials must have characteristics suitable to the product and be perfectly closed and sealed to prevent the contents from flowing out.
- The machine consists of a rotary table, which makes the pallet turn, and a spool carriage which unwinds and stretches the film.
- The machine is equipped with a series of safety devices designed to avoid any injuries to the operator or other persons using the machine. It comes in different models to satisfy different market needs.
- Stretch film spools commonly available on the market are used for load wrapping.
- This machine is normally installed in workshops or industrial environments protected from the atmospheric agents.



**Danger - warning**

**Using this machine in explosive environments or when exposed to atmospheric agents is strictly forbidden.**

- The pallet loading and unloading are performed by the user, who can also insert and cut the film.
- Only one operator is required for its use.



The illustration shows, for information purposes only, the machine models, and the legend lists the parts.

**Legend:**

1. Slide shaft
2. Table motor
3. Rotary table
4. Carriage motor
5. Control panel
6. Spool carriage
7. Base
8. Loading/unloading ramp

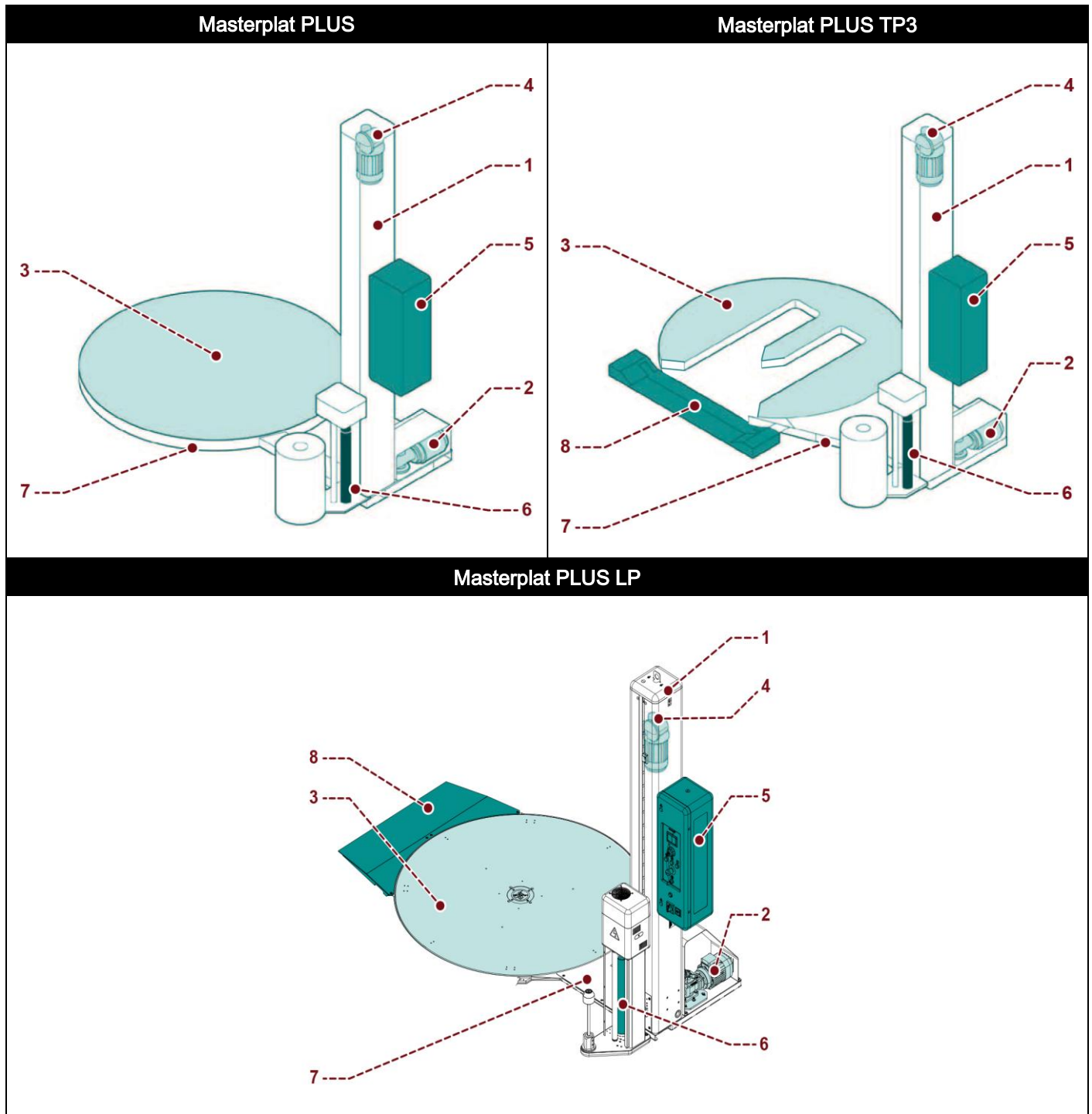

### 3.1.1. MACHINE MODELS DESCRIPTION

Type of machine	General features
Masterplat PLUS FRD Masterplat PLUS TP3 FRD Masterplat PLUS LP FRD	Masterplat with spool carriage of "FRD" type or "FRD" type for mesh.
Masterplat PLUS PGS Masterplat PLUS TP3 PGS Masterplat PLUS LP PGS	Masterplat with spool carriage of "PGS" type.
Masterplat FREEZER	Maintaining the same features as the standard machine, this model can operate at an ambient temperature of $-30 \div +40^{\circ}\text{C}$ . The control panel features a heating system to protect devices against low temperatures.
Masterplat INOX	Maintaining the same features as the standard machine, this model is made of stainless steel to allow working in particular environments. On request, it can feature a control panel with heating system to protect devices against low temperatures. In this case the machine can operate at an ambient temperature of $-30 \div +40^{\circ}\text{C}$ .

Table: Spool carriage features

Spool carriage type	General features
FRD	Spool carriage of "FRD" and "FRD for mesh" type with friction roller, mechanical brake and manual adjustment of film stretch.
PGS	Spool carriage of "PGS" type with motorised pre-stretching rollers and electronically controlled film tensioning. Pre-stretch is fixed (250%).

### 3.2. DESCRIPTION OF THE OPERATION CYCLE

#### Phase 1

The pallet is loaded on the rotary table against the bracket on the plate and the operator ties the film ends in the striker bracket slot.



#### Caution - warning

Risk of crushing upper limbs.  
Do not insert the film in the gripper by hand.

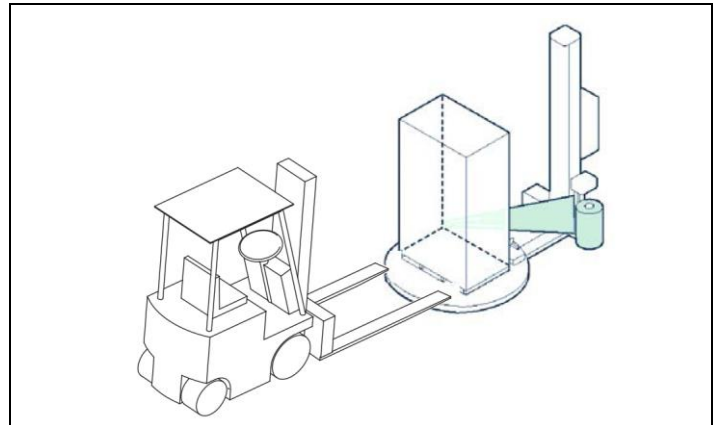

#### Phase 2

Once the cycle has started, the rotary table starts to turn, while the spool carriage unwinds the film for the entire height, according to pre-set parameters.

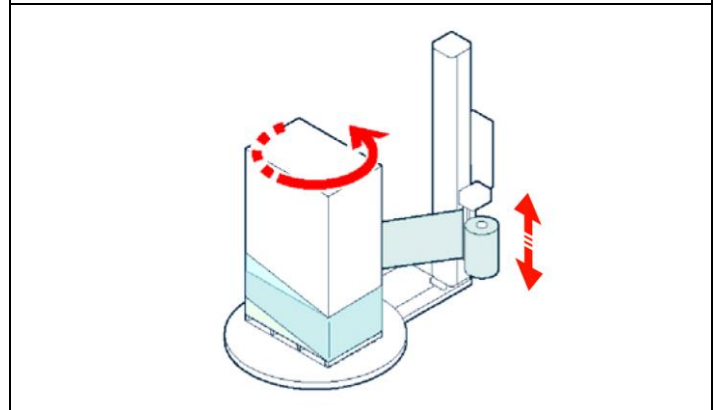

#### Phase 3

Once the wrapping phase has ended, the machine stops and film hot cutting and welding are automatically performed (CW version).

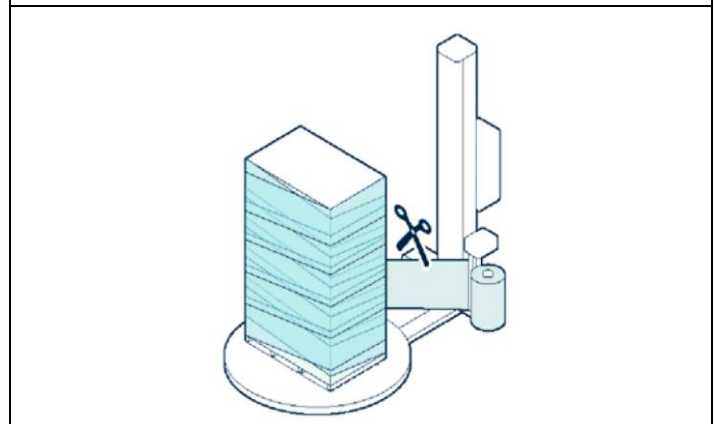

#### Phase 4

The operator unloads the pallet.  
The cycle is complete and the machine is ready to start a new cycle.

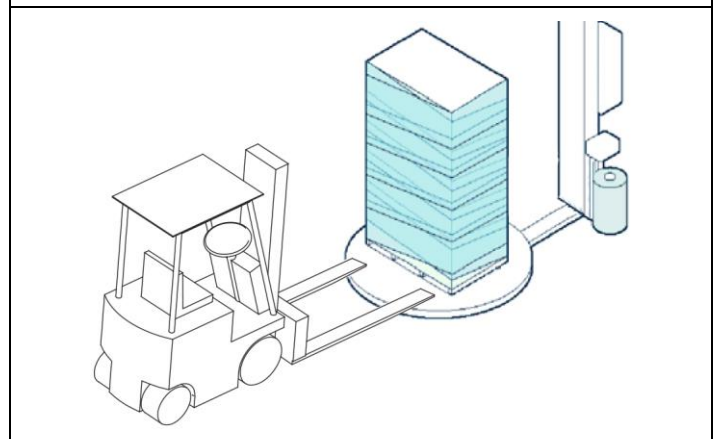

### 3.3. SAFETY DEVICE DESCRIPTION

The figure shows the position of the devices on the machine.

1. **Spool carriage base microswitch:**  
it stops the downstroke if there are obstacles under the carriage.
2. **Spool carriage mechanical locking device:**  
it immediately stops the fall of the spool carriage in case of accidental breakage of the lifting chain.
3. **Main switch:**  
it enables and disables the power supply. It can be locked to prevent unauthorised persons from enabling it during machine adjustment and maintenance phases.
4. **Acoustic signal:** it signals the wrapping cycle start.
5. **Fork infeed safety photocell:** it detects the presence of forks on the pallet loading/unloading ramp, stopping the table rotation.

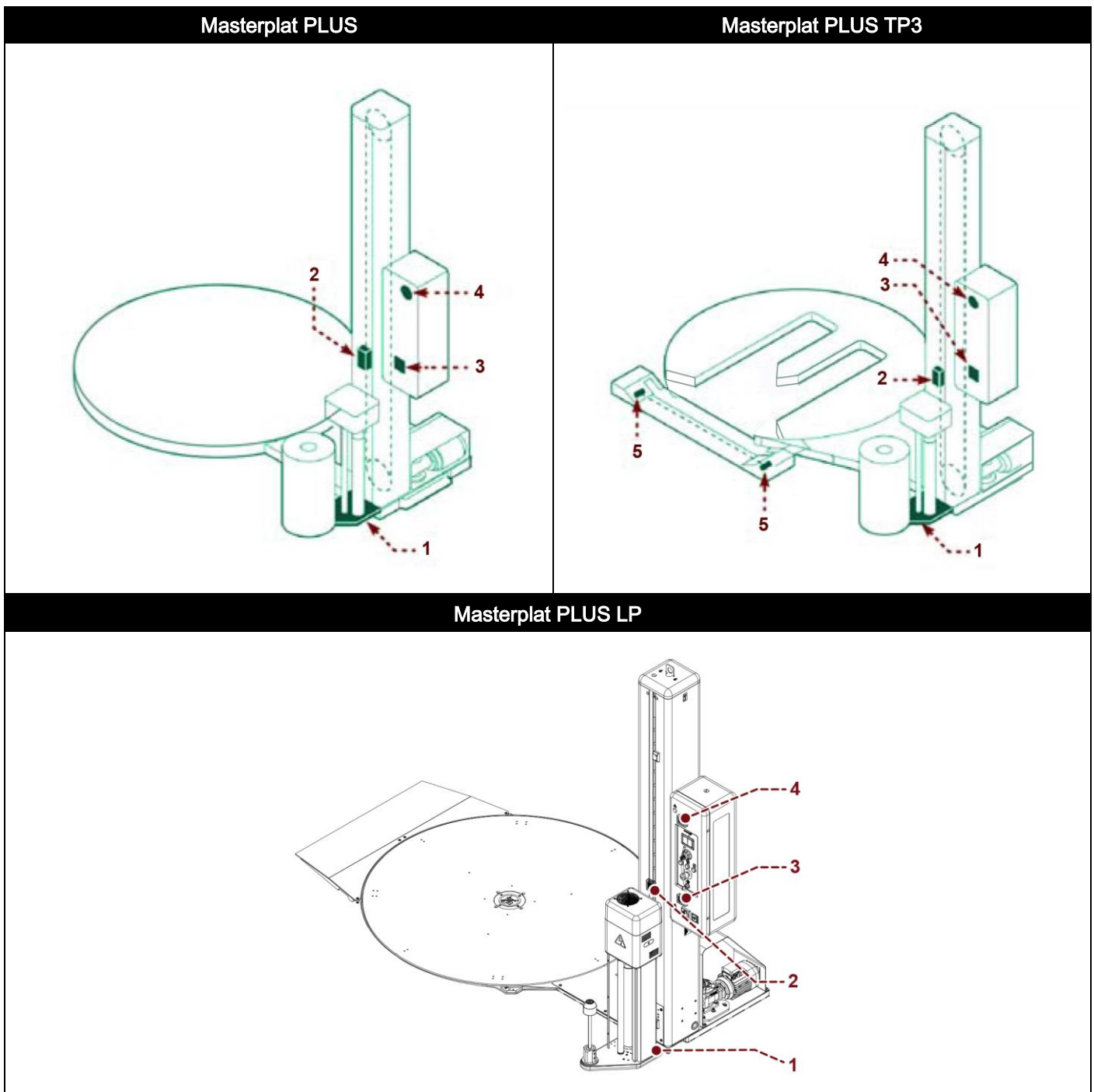

**6. Emergency button:**

when pressed, it immediately stops the machine in emergency conditions.  
To reset, rotate the button in the direction indicated by the arrow.



**Danger - warning**

When the emergency button is pressed, the terminals of the motors may still be powered.

**7. Key-operated switch:**

it overrides the emergency condition of the spool carriage.  
If it is kept turned, it allows to activate the carriage upstroke with the user interface manual controls.

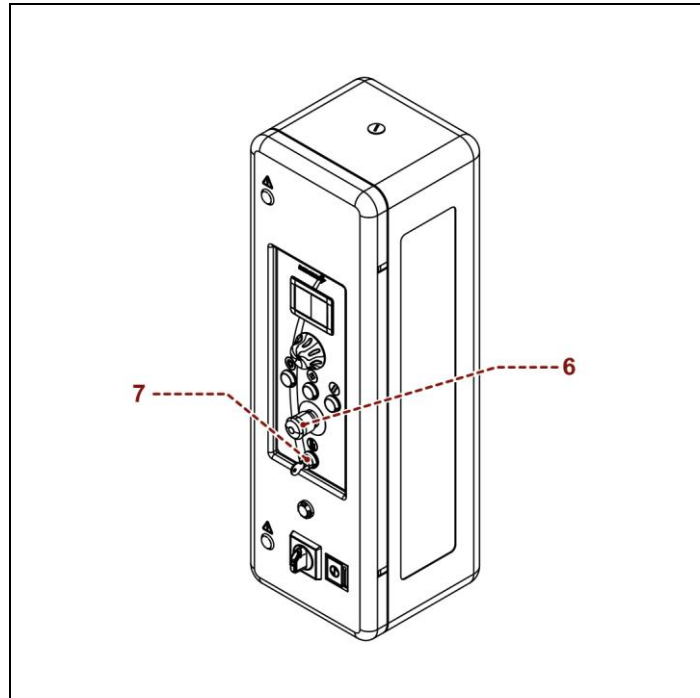

### 3.4. DESCRIPTION OF ELECTRICAL DEVICES

The figure shows the position of the devices on the machine.

1. **Gearmotor:**  
it activates the table rotation.
2. **Gearmotor:**  
it activates the spool carriage movement.
3. **Carriage limit microswitch:**  
it is activated when the spool carriage reaches the minimum and maximum wrapping height.
4. **Microswitch:**  
it stops the downstroke if there are obstacles under the spool carriage.
5. **Photocell:**  
it detects the height and the presence of the load to be wrapped.
6. **"Load cell" sensor:**  
it detects the film tensioning and enables the variation of the pre-stretching roller speed.
7. **Electric motor:**  
it powers pre-stretching rollers.
8. **Sensor:**  
it enables the synchronised stop of the rotary table.
9. **Carriage lifting sensor:**  
it determines the position in which the carriage must be stopped to start the processing.



**Important**

For further details see the wiring diagram.

**Masterplat PLUS**

**Masterplat PLUS TP3**

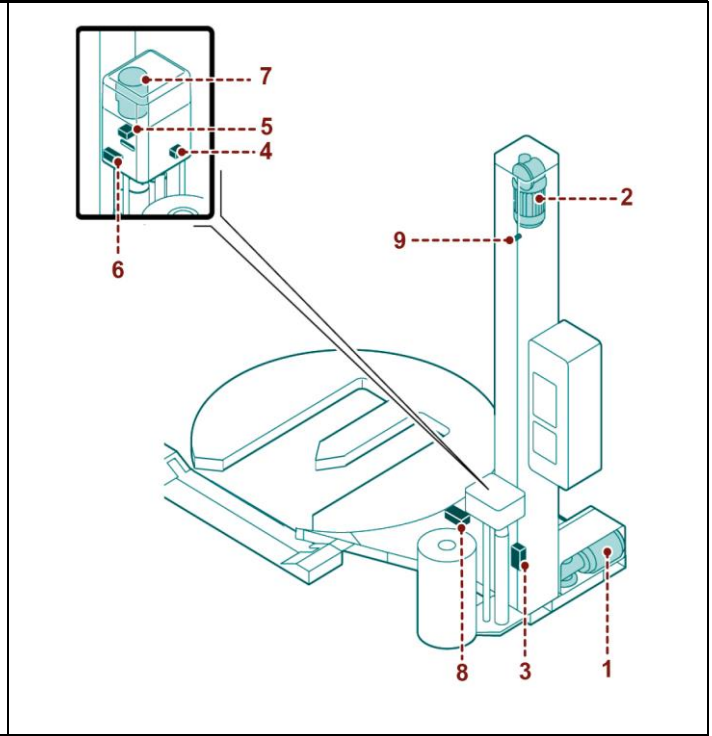
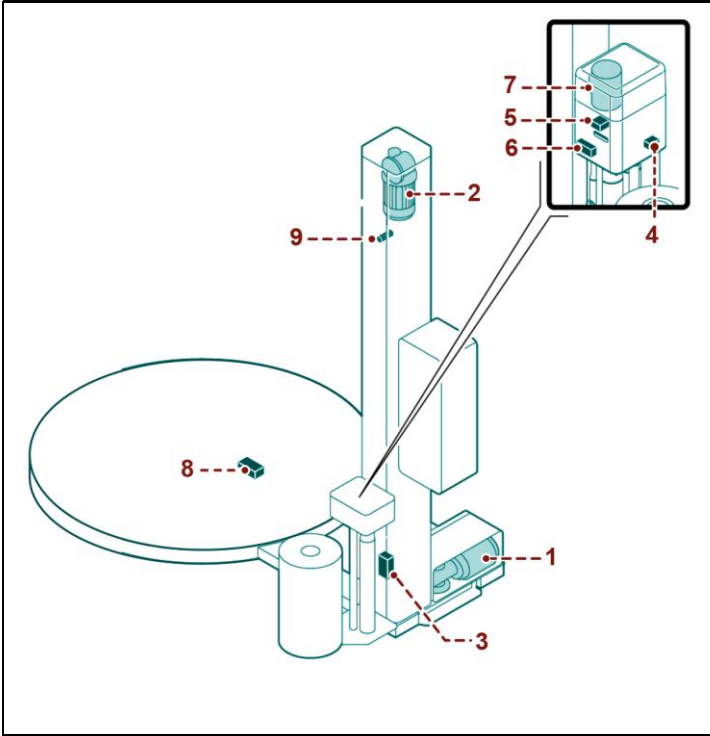

**Masterplat PLUS LP**

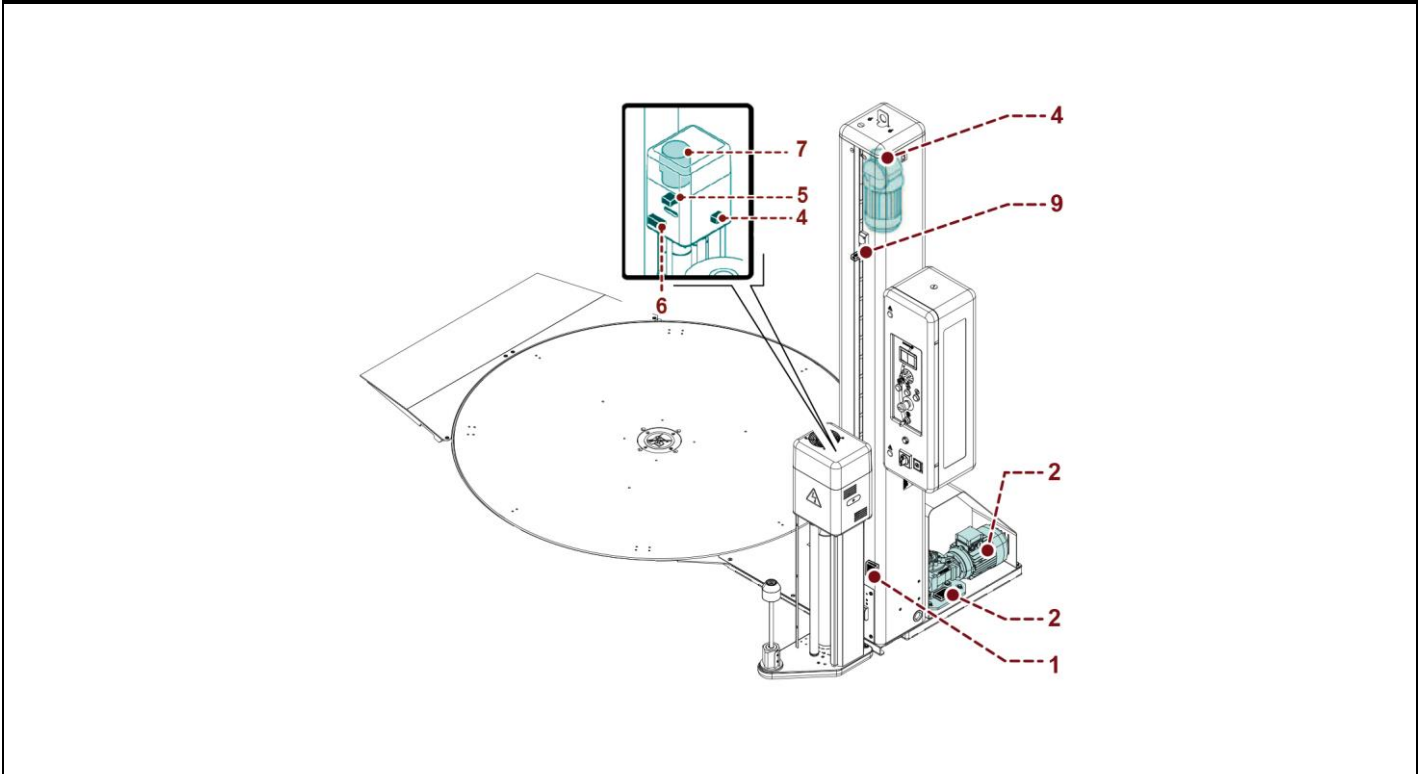

### 3.4.1. REMOTE CONTROL SOFTWARE

The Machine features a remote control Software (1).

Through a sensor on the roller (2), the system controls film use, end of the spool and general info.



**Important**

For further details see the wiring diagram.

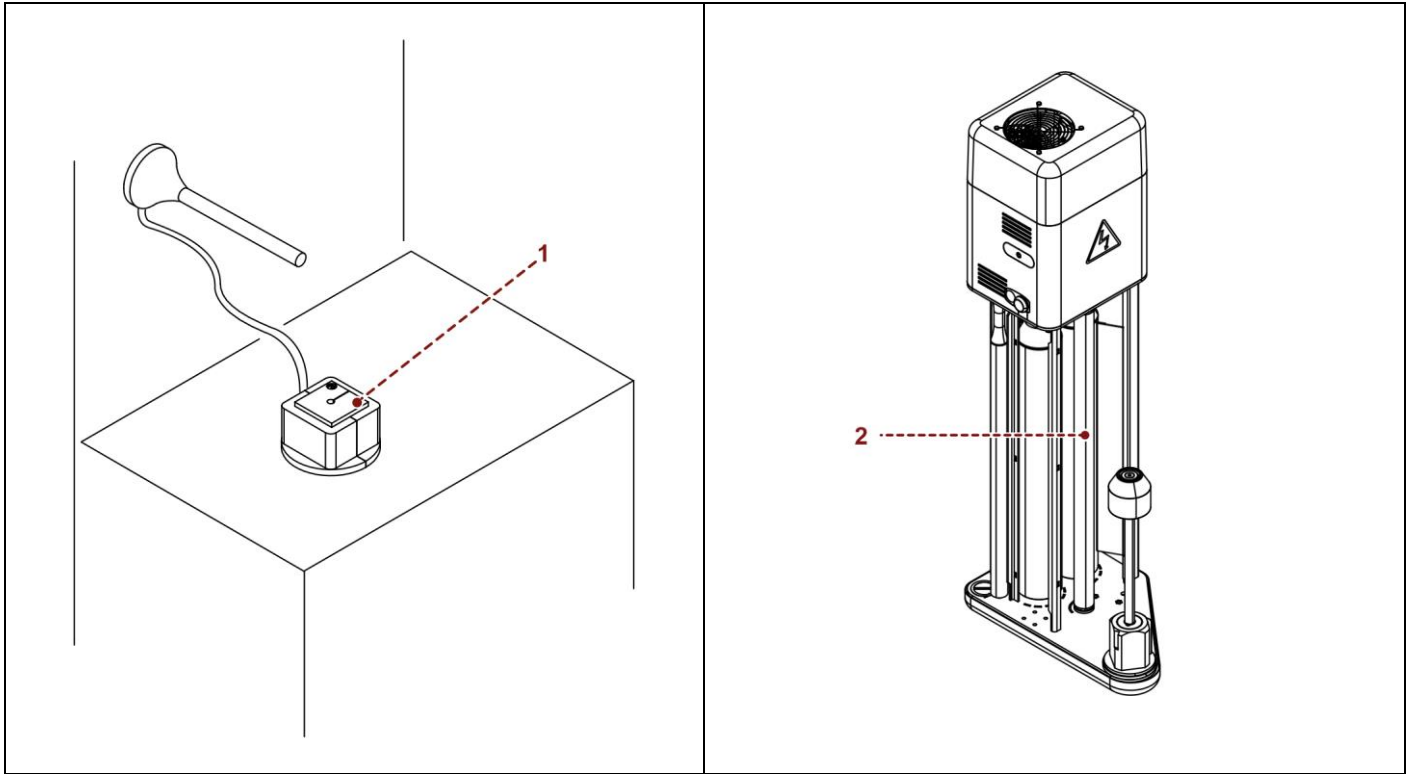



### 3.5. DESCRIPTION OF PNEUMATIC DEVICES

The figure shows the position of the devices on the machine.

#### 1. Pressure regulator with filter and pressure gauge

To adjust the general pressure of the pneumatic system.

Turn the knob to change the pressure values indicated on the pressure gauge.



#### Important

For further details see the pneumatic diagram.

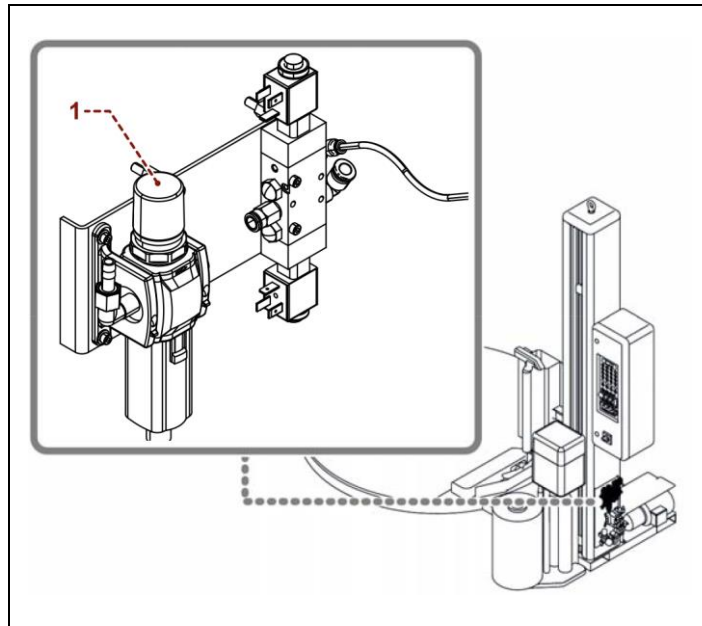

### 3.6. DESCRIPTION OF ACCESSORIES ON REQUEST

To increase the machine performance and versatility, the Manufacturer makes available the following accessories.

1. **Pneumatic presser:**  
 pneumatically controlled device for load stabilisation. It is supplied with pneumatic cylinder with rod (Max. stroke 800 mm).  
 The height must be adjusted according to the size of the product to be wrapped.  
 An air supply system is required for its operation.
2. **Pallet loading/unloading ramp:**  
 it facilitates these operations through fork lifting devices (hand pallet trucks).

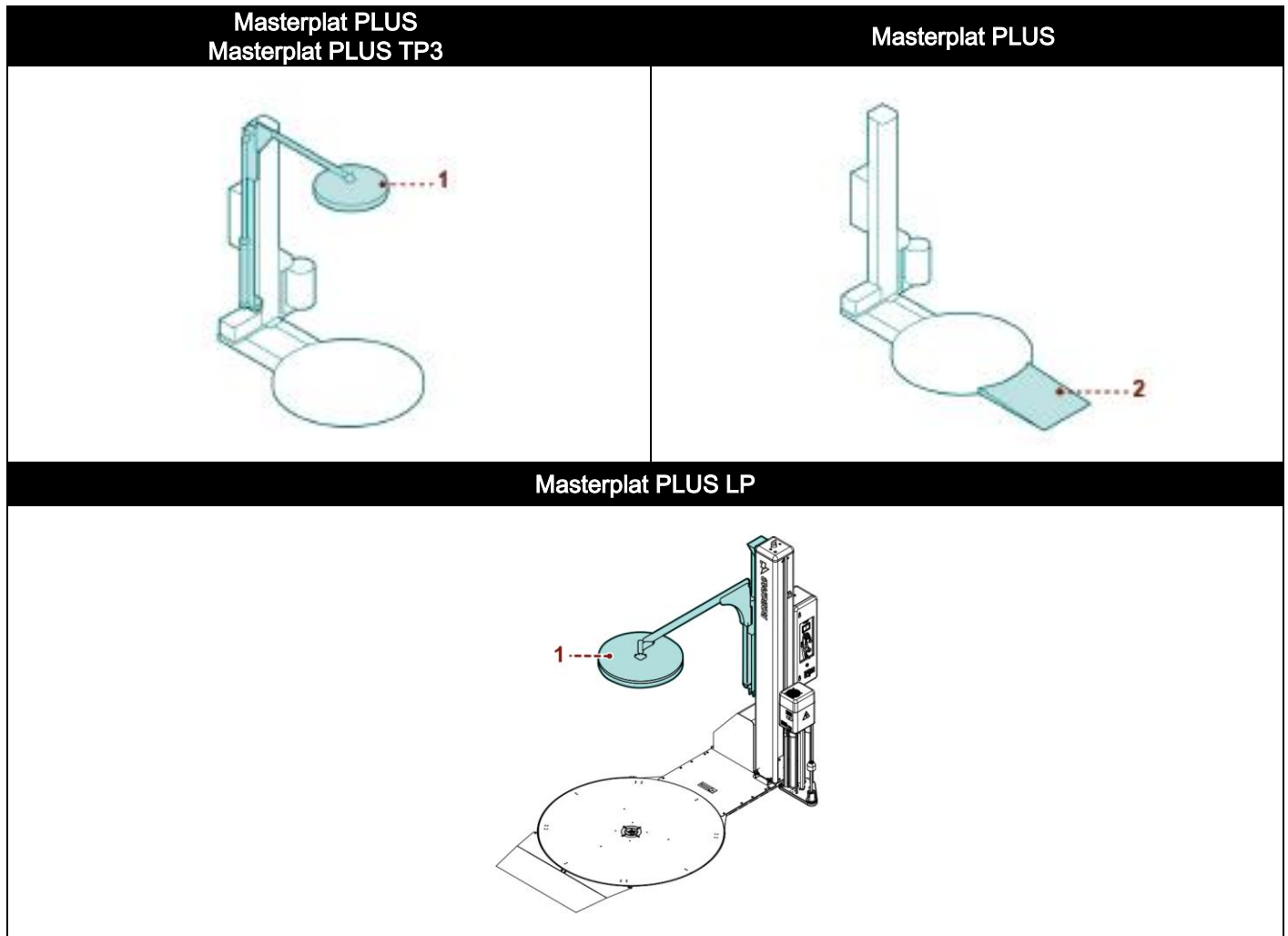

### 3. Pallet loading/unloading ramps:

one ramp (3) is supplied as a standard and can be placed in 5 positions (every 45°).

It is possible to purchase a second and a third optional ramp or a 270° ramp (3A) (3 pieces) which covers all the positions.



#### Important

During pallet loading/unloading operations it is recommended not to get on the ramps with the forklift truck.

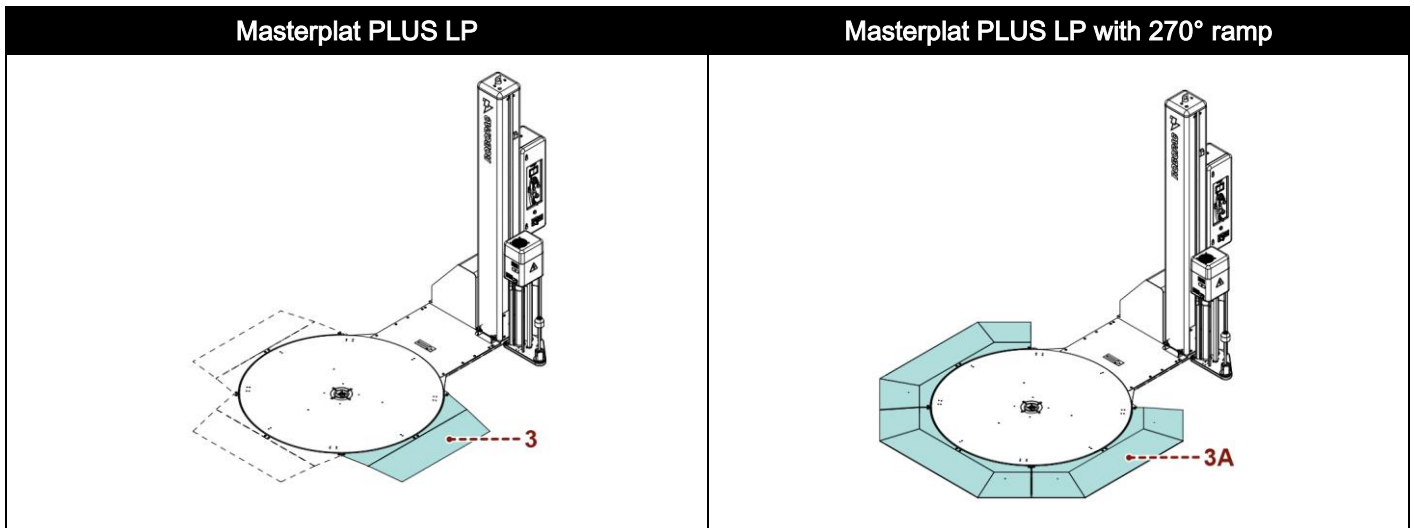

### 4. Lifting frame:

Structure which allows lifting the machine from the ground when the floor must be washed or for loading with electric hand pallet trucks.

- **Underground installation template:**  
profiled structure for base underground installation.
- **Rotary table (ø1800):**  
it is used to wrap pallets with a size greater than the standard one.
- **Brake shaft for mesh (only for "FRD" spool carriages):**  
it is used to obtain a correct tensioning of the mesh.
- **Slide shaft (2400 - 2800 - 3100 mm):**  
it is used to wrap pallets which are higher than the standard ones.

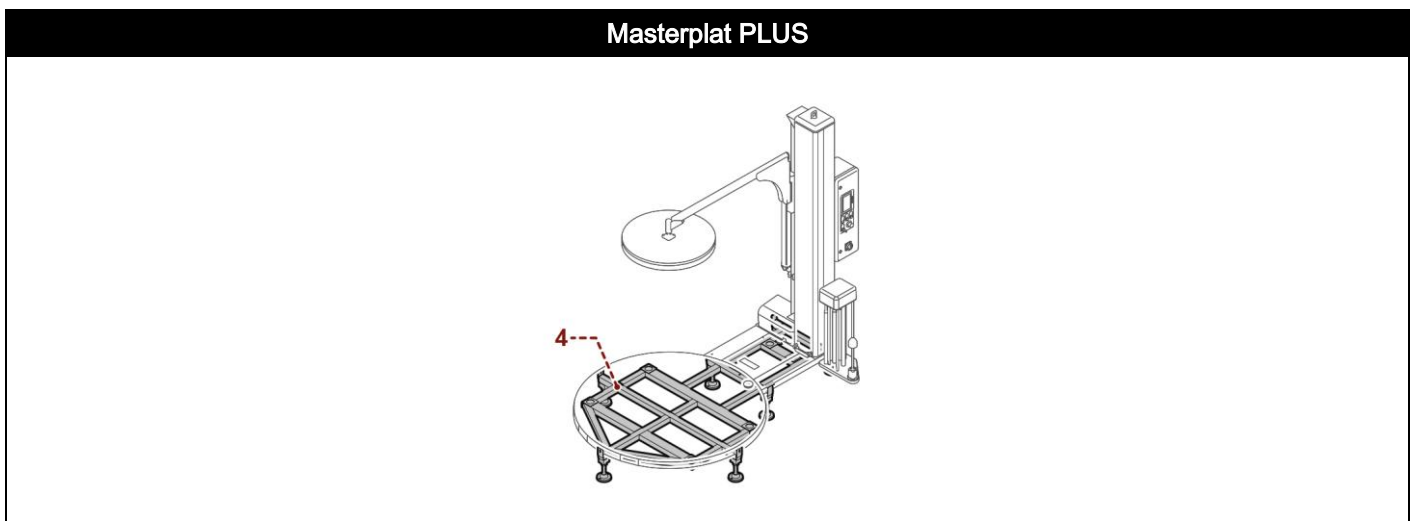

5. **Film reinforcement tool:**  
it is used to create a film reinforcement on the base of the product or on the pallet.
6. **Spool shaft D = 50 and D = 76 for coreless spools .**

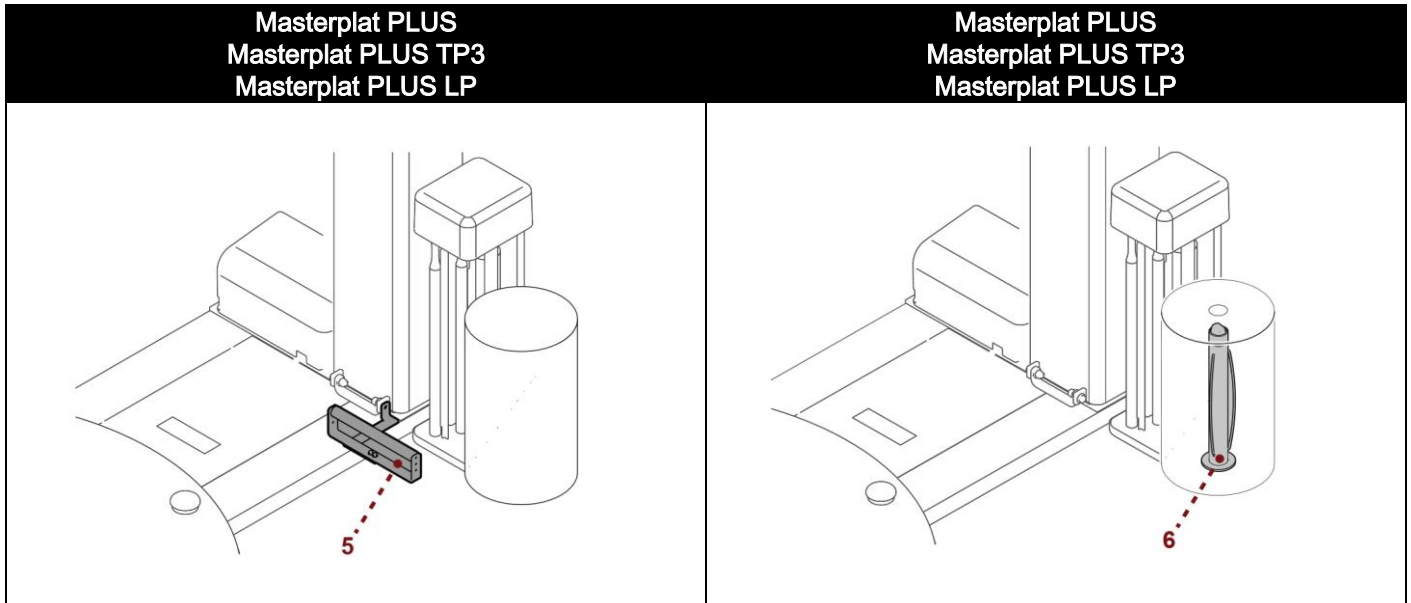

**7. Roll-container stop device:**

this system is suitable for Roll-container (1) wrapping.

In this case, infeed ramp (2) position is bound to stop device position (3), in fact the recommended ramp type is the one indicated in the figure (270°).



**Important**

If the Roll-container stop device (3) is used, set the film stretch (4) to low intensity to avoid load overturning.

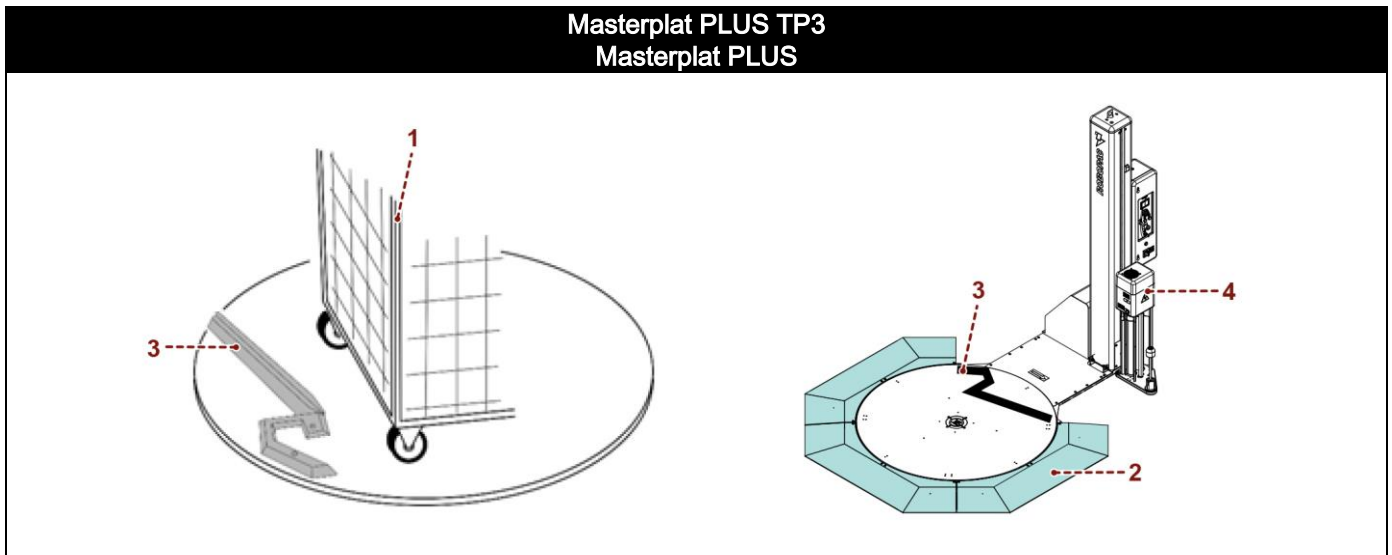

**Roll-container insertion**

Insert Roll-container (1) as follows:

- A. Insert a fixed wheel (6) inside area (5), as indicated.
- B. Rotate Roll-container (1) until bracket stops (3), as indicated.

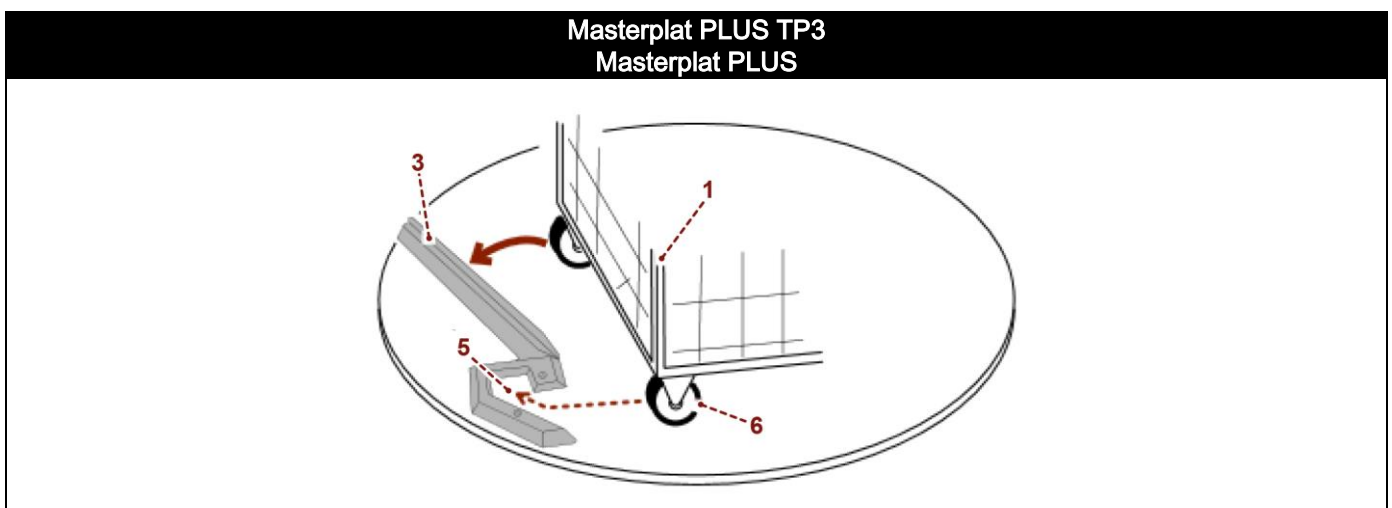

### 3.7. "MASTERPLAT PLUS" TECHNICAL DATA

The illustration and the table include the machine dimensional specifications and technical data.

#### FRD

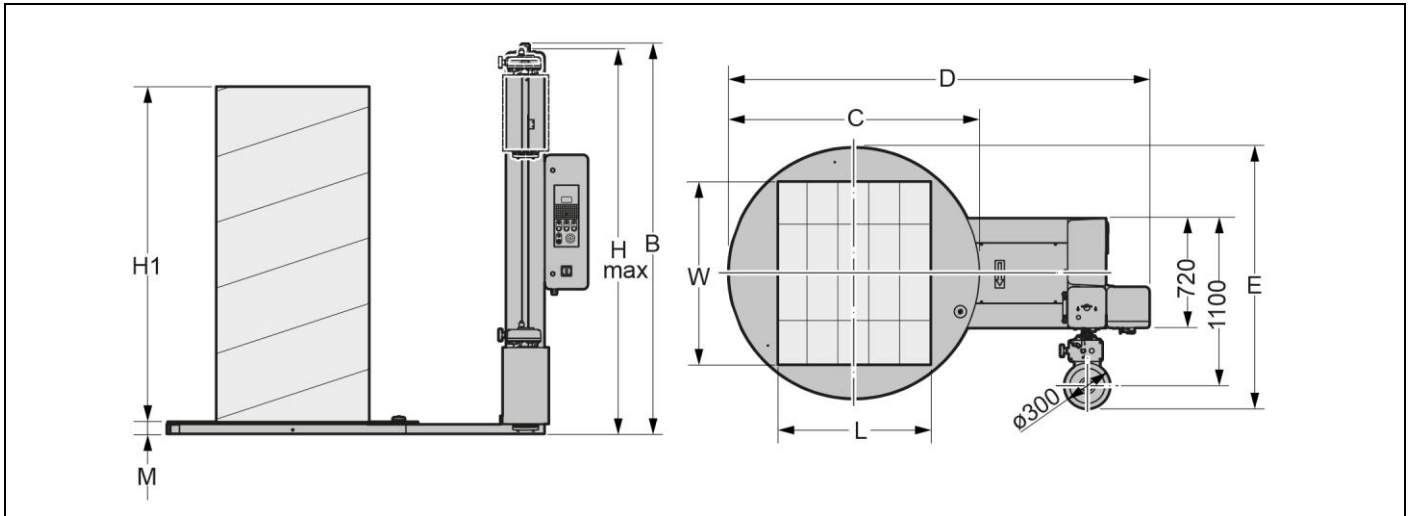

#### PGS

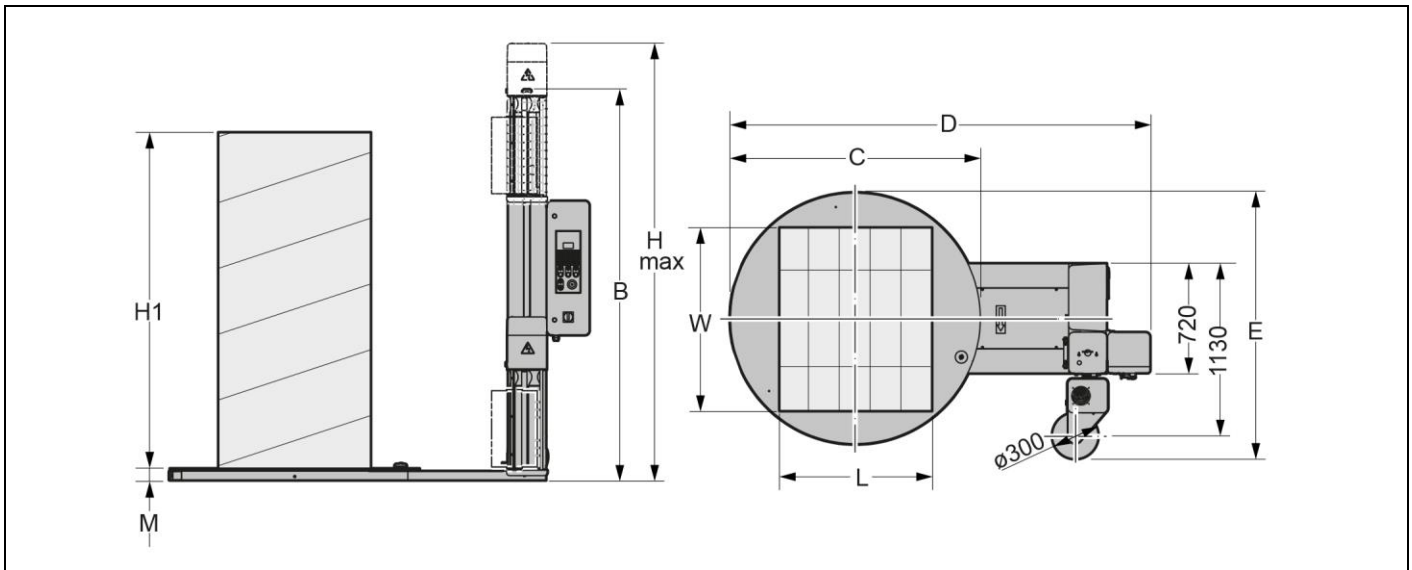

### 3.7.1. "MASTERPLAT PLUS FRD" MACHINE AND PALLET DIMENSIONS

Description	Masterplat PLUS FRD			
	Standard	Optional	Optional	Optional
Shaft height	2200	2400	2800	3100
<b>A</b>				
<b>H</b>	2530	2730	3130	3430
<b>B</b>	2560	2760	3160	3460
H1	2200	2400	2800	3100
<b>M</b>	77.5	77.5	77.5	77.5
Load overall dimensions	∅ 1650	∅ 1800	-	-
<b>C</b>	1650	1800	-	-
<b>D</b>	2760.5	2835.5	-	-
<b>E</b>	1715	1790	-	-
<b>F</b>				
<b>G</b>				
<b>N</b>				
<b>L</b>	1000	1200	-	-
<b>W</b>	1200	1200	-	-
Weight (kg)	2000	2000	-	-

### 3.7.2. "MASTERPLAT PLUS PGS" MACHINE AND PALLET DIMENSIONS

Description	Masterplat PLUS PGS			
	Standard	Optional	Optional	Optional
Shaft height	2200	2400	2800	3100
<b>A</b>				
<b>H</b>	2865	3065	3465	3765
<b>B</b>	2560	2760	3160	3460
H1	2200	2400	2800	3100
<b>M</b>	77.5	77.5	77.5	77.5
Load overall dimensions	∅ 1650	∅ 1800	-	-
<b>C</b>	1650	1800	-	-
<b>D</b>	2760.5	2835.5	-	-
<b>E</b>	1745	1820	-	-
<b>F</b>				
<b>G</b>				
<b>N</b>				
<b>L</b>	1000	1200	-	-
<b>W</b>	1200	1200	-	-
Weight (kg)	2000	2000	-	-

### 3.7.3. "MASTERPLAT PLUS PGS USA" MACHINE AND PALLET DIMENSIONS

Description	Masterplat PLUS PGS			
	Standard	Optional	Optional	Optional
Shaft height	2200	2400	2800	-
<b>A</b>				
<b>H</b>	2865	3065	3465	-
<b>B</b>	2560	2760	3160	-
H1	2200	2400	2800	-
<b>M</b>	77.5	77.5	77.5	-
Load overall dimensions	Ø 1650	-	-	-
<b>C</b>	1650	-	-	-
<b>D</b>	2760.5	-	-	-
<b>E</b>	1745	-	-	-
<b>F</b>				
<b>G</b>				
<b>N</b>				
<b>L</b>	1000	-	-	-
<b>W</b>	1200	-	-	-
Weight (kg)	2000	-	-	-

### 3.7.4. MACHINE TECHNICAL FEATURES

Description	Unit of measurement	Value
Supply voltage	V	220-240 1Ph
		220-240 3Ph
		380-415 3Ph+N
		120 1Ph (for USA)
Power supply frequency	Hz	50/60   60 (for USA)
Installed power	kW	1.5 (Masterplat PLUS FRD)
		1.9 (Masterplat PLUS PGS)
Table rotation speed	rpm	C = 1650 5 - 12
		C = 1800 5 - 11
Carriage upstroke / downstroke speed	m/min.	1.4 - 4
Maximum capacity	kg	2000
Overall weight	kg	395÷455
Ambient operating temperature.	°C	0÷40
Ambient operating temperature (FREEZER model)	°C	-30 ÷ +40 <sup>(1)</sup>

<sup>(1)</sup> On request, also the "INOX" model can operate at this temperature.

### 3.7.5. PRESSER TECHNICAL FEATURES

Description	Value
Working pressure	6 (±1) bar (0.6±0.1 MPa)
Pneumatic cylinder with rod	H = 2200/2400 2800/3100 Air consumption 11 NI/min.



### 3.7.6. "MASTERPLAT PLUS FRD" AND "PGS" SPOOL CHARACTERISTICS

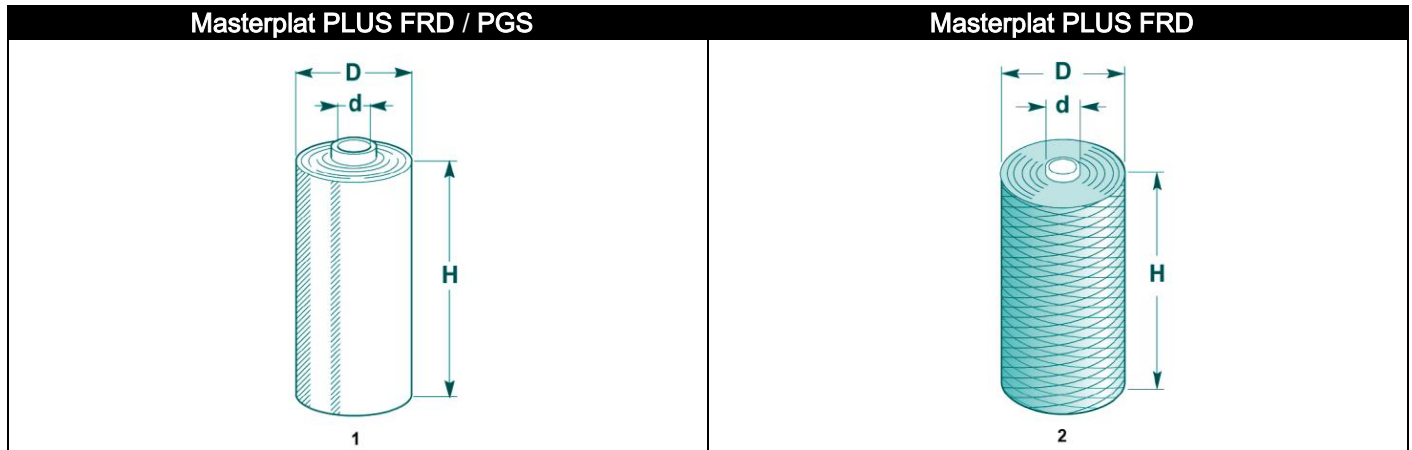

Description	Unit of measurement	Value
<b>Film spool dimensions (1)</b>		
Maximum outer diameter (D)	mm	300
Spool height (H)	mm	500
Film thickness	µm	17÷35
Internal diameter (d)	mm	76
Max. weight	kg	20
<b>Mesh spool dimensions (2)</b>		
Maximum outer diameter (D)	mm	300
Spool height (H)	mm	500
Internal diameter (d)	mm	76
Max. weight	kg	20

### 3.8. "MASTERPLAT PLUS LP FRD" AND "PGS" TECHNICAL DATA

The illustration and the table include the machine dimensional specifications and technical data.

#### FRD

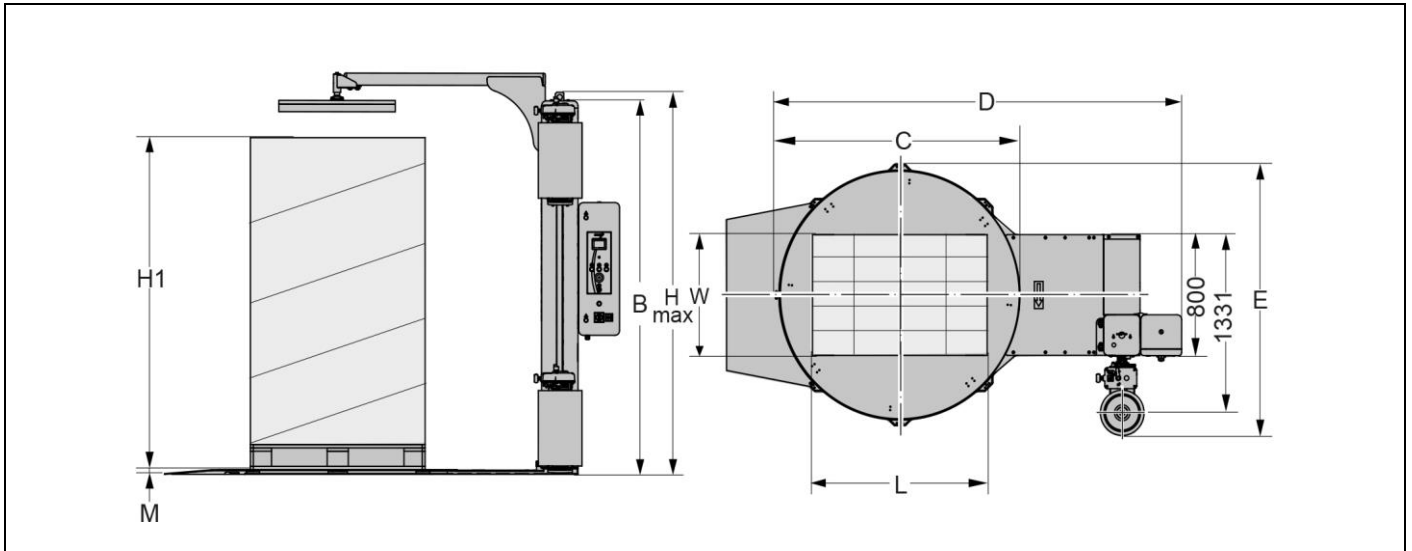

#### PGS

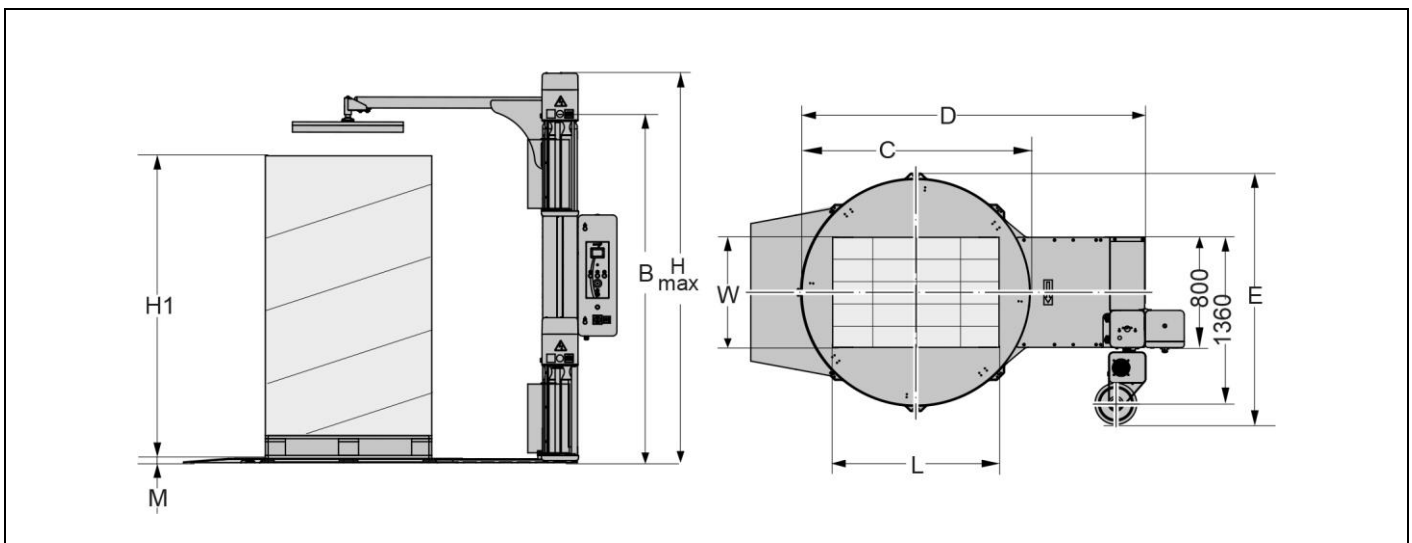

### 3.8.1. "MASTERPLAT PLUS LP FRD" MACHINE AND PALLET DIMENSIONS

Description	Masterplat PLUS LP FRD			
	Standard	Optional	Optional	Optional
Shaft height	2200	2400	2800	3100
<b>A</b>				
<b>H max</b>	2502	2702	3102	3402
<b>B</b>	2532	2732	3132	3432
H1	2200	2400	2800	3100
<b>M</b>	31	31	31	31
Load overall dimensions	∅ 1650	-	-	-
<b>C</b>	1650	-	-	-
<b>D</b>	2801.5	-	-	-
<b>E</b>	1826	-	-	-
<b>F</b>				
<b>G</b>				
<b>N</b>				
<b>L</b>	1000	-	-	-
<b>W</b>	1200	-	-	-
Weight (kg)	1200	-	-	-

### 3.8.2. "MASTERPLAT PLUS LP PGS" MACHINE AND PALLET DIMENSIONS

Description	Masterplat PLUS LP PGS			
	Standard	Optional	Optional	Optional
Shaft height	2200	2400	2800	3100
<b>A</b>				
<b>H max</b>	2837	3037	3437	3737
<b>B</b>	2532	2732	3132	3132
H1	2200	2400	2800	3100
<b>M</b>	31	31	31	31
Load overall dimensions	∅ 1650	-	-	-
<b>C</b>	1650	-	-	-
<b>D</b>	2801.50	-	-	-
<b>E</b>	1826	-	-	-
<b>F</b>				
<b>G</b>				
<b>N</b>				
<b>L</b>	1000	-	-	-
<b>W</b>	1200	-	-	-
Weight (kg)	1200	-	-	-

### 3.8.3. "MASTERPLAT PLUS LP PGS USA" MACHINE AND PALLET DIMENSIONS

Description	Masterplat PLUS LP PGS			
	Standard	Optional	Optional	Optional
Shaft height	2200	2400	2800	-
<b>A</b>				
<b>H</b>	2837	3037	3437	-
<b>B</b>	2532	2732	3132	-
H1	2200	2400	2800	-
<b>M</b>	31	31	31	-
Load overall dimensions	∅ 1650	-	-	-
<b>C</b>	1650	-	-	-
<b>D</b>	2801.50	-	-	-
<b>E</b>	1797	-	-	-
<b>F</b>				
<b>G</b>				
<b>N</b>				
<b>L</b>	1000	-	-	-
<b>W</b>	1200	-	-	-
Weight (kg)	1200	-	-	-

### 3.8.4. MACHINE TECHNICAL FEATURES

Description	Unit of measurement	Value
Supply voltage	V	220-240 1Ph
		220-240 3Ph
		380-415 3Ph+N
		120 1Ph (for USA)
Power supply frequency	Hz	50/60   60 (for USA)
Installed power	kW	1.5 (Masterplat PLUS FRD)
		1.9 (Masterplat PLUS PGS)
Table rotation speed	rpm	C = 1650 5 - 12
		C = 1800 5 - 11
Carriage upstroke / downstroke speed	m/min.	1.4 - 4
Maximum capacity	kg	1200
Overall weight	kg	470÷580
Ambient operating temperature.	°C	0÷40
Ambient operating temperature (FREEZER model)	°C	-30 ÷ +40 <sup>(1)</sup>

<sup>(1)</sup> On request, also the "INOX" model can operate at this temperature.

### 3.8.5. PRESSER TECHNICAL FEATURES

Description	Value
Working pressure	6 (±1) bar (0.6±0.1 MPa)
Pneumatic cylinder with rod	H = 2200/2400 2800/3100 Air consumption 11 NI/min.

### 3.8.6. "MASTERPLAT PLUS LP FRD" AND "PGS" SPOOL CHARACTERISTICS

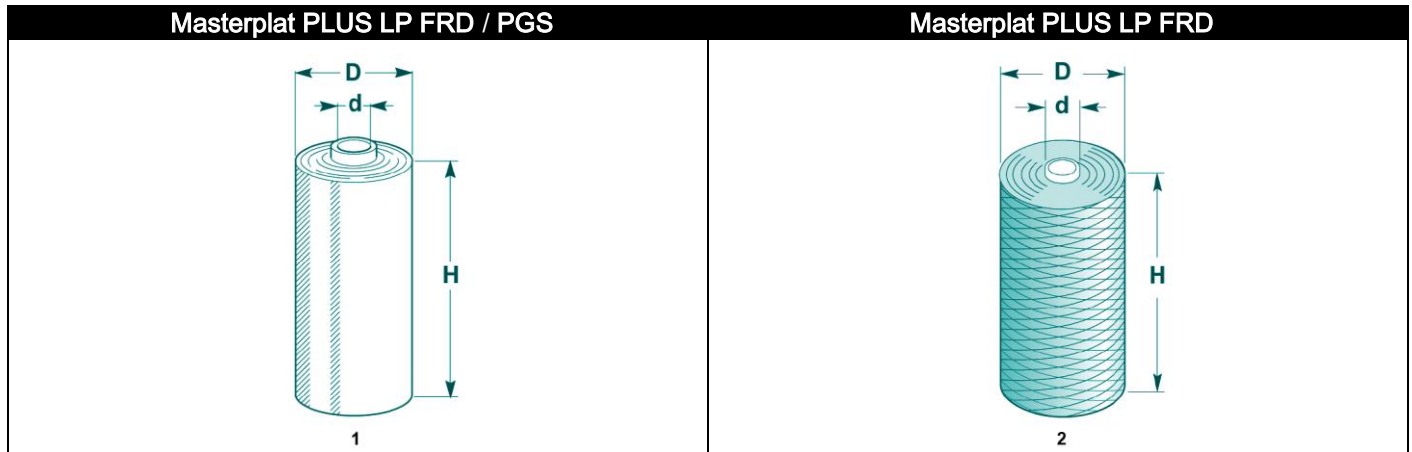

Description	Unit of measurement	Value
<b>Film spool dimensions (1)</b>		
Maximum outer diameter (D)	mm	300
Spool height (H)	mm	500
Film thickness	µm	17÷35
Internal diameter (d)	mm	76
Max. weight	kg	20
<b>Mesh spool dimensions (2)</b>		
Maximum outer diameter (D)	mm	300
Spool height (H)	mm	500
Internal diameter (d)	mm	76
Max. weight	kg	20

### 3.9. "MASTERPLAT PLUS TP3 FRD" AND "PGS" TECHNICAL DATA

The illustration and the table include the machine dimensional specifications and technical data.

#### FRD

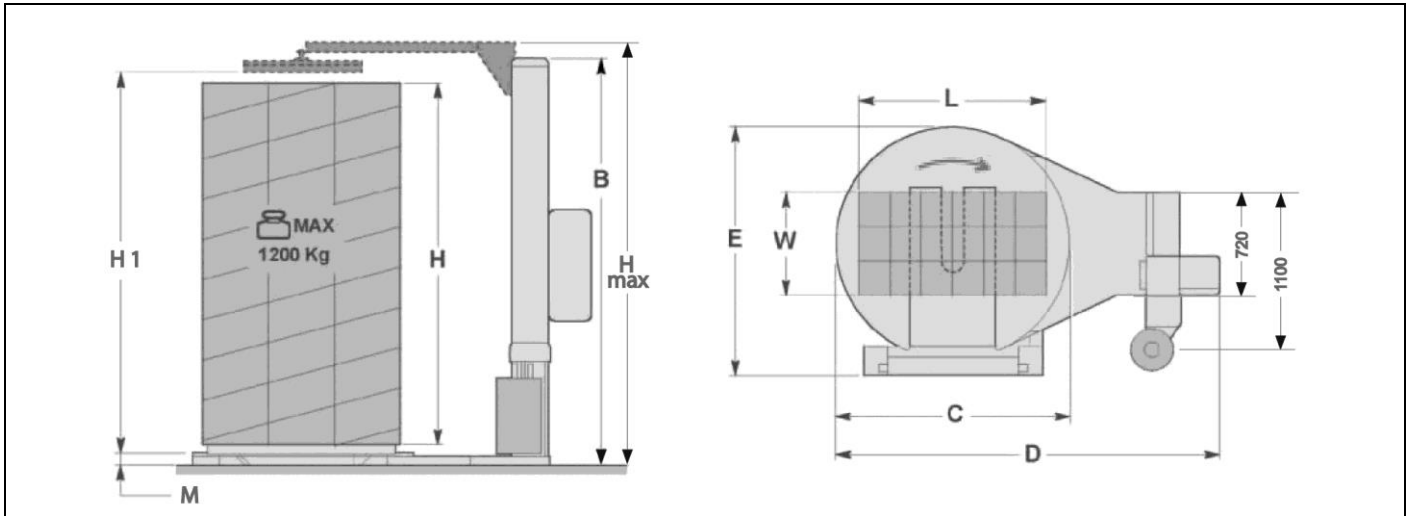

#### PGS

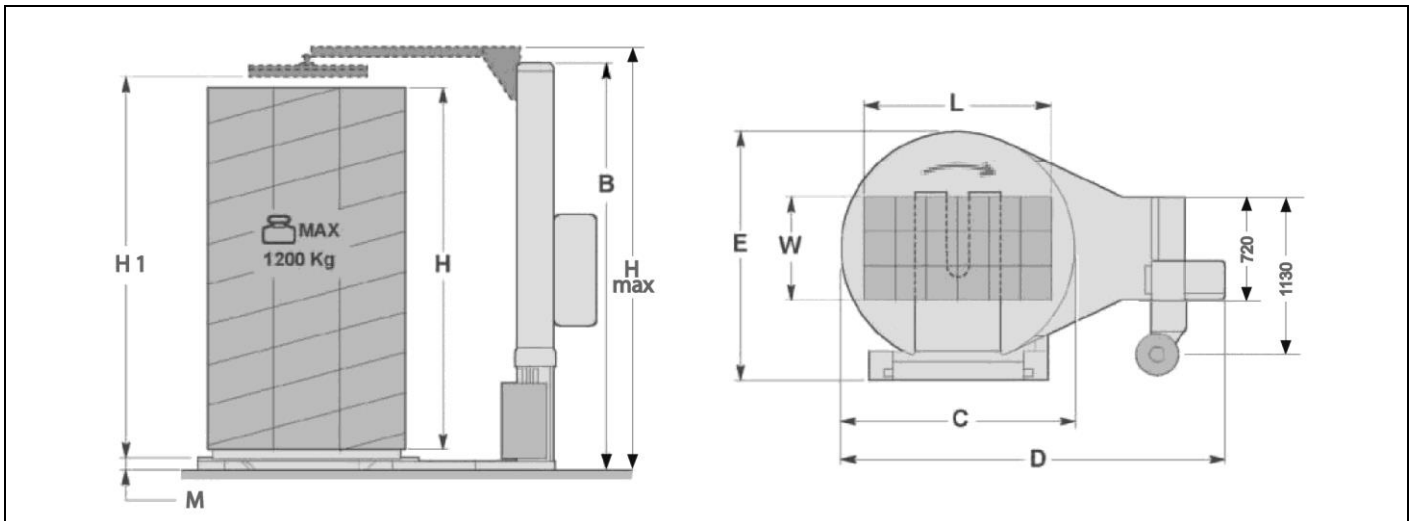

### 3.9.1. "MASTERPLAT PLUS TP3 FRD" MACHINE AND PALLET DIMENSIONS

Description	Masterplat PLUS TP3 FRD			
	Standard	Optional	Optional	Optional
Shaft height	2200	2400	2800	3100
<b>A</b>				
<b>H</b>	2540	2740	3140	3440
<b>B</b>	2570	2770	3170	3470
H1	2200	2400	2800	3100
<b>M</b>	73.5	77.5	77.5	77.5
Load overall dimensions	∅ 1500	∅ 1650	∅ 1800	-
<b>C</b>	1500	1650	1800	-
<b>D</b>	2625	2775	2850	-
<b>E</b>	1650	1725	1800	-
<b>F</b>	1645	1765	1950	-
<b>G</b>	620	620	620	-
<b>N</b>				
<b>L</b>	800	1000	1200	-
<b>W</b>	1200	1200	1200	-
Weight (kg)	1200	1500	1500	-

### 3.9.2. "MASTERPLAT PLUS TP3 PGS" MACHINE AND PALLET DIMENSIONS

Description	Masterplat PLUS TP3 PGS			
	Standard	Optional	Optional	Optional
Shaft height	2200	2400	2800	3100
<b>A</b>				
<b>H</b>	2875	3075	3475	3775
<b>B</b>	2570	2770	3170	3470
H1	2200	2400	2800	3100
<b>M</b>	77.5	77.5	77.5	77.5
Load overall dimensions	∅ 1650	∅ 1800	-	-
<b>C</b>	1650	1800	-	-
<b>D</b>	2775	2850	-	-
<b>E</b>	1755	1830	-	-
<b>F</b>	1765	1950	-	-
<b>G</b>	620	620	-	-
<b>N</b>				
<b>L</b>	1000	1000	-	-
<b>W</b>	1200	1200	-	-
Weight (kg)	1500	1500	-	-

### 3.9.3. MACHINE TECHNICAL FEATURES

Description		Unit of measurement	Value
Supply voltage		V	220-240 1Ph
			220-240 3Ph
			380-415 3Ph+N
			120 1Ph
Power supply frequency		Hz	50/60
Installed power		kW	1.5 (Masterplat PLUS FRD)
			1.9 (Masterplat PLUS PGS)
Table rotation speed	C = 1650	rpm	5 - 12
	C = 1800		5 - 11
Carriage upstroke / downstroke speed		m/min.	1.4 - 4
Maximum capacity		kg	1500
Overall weight		kg	525 (Masterplat PLUS TP3 FRD)
			550 (Masterplat PLUS TP3 PGS)
Ambient operating temperature.		°C	0÷40
Ambient operating temperature (FREEZER model)		°C	-30 ÷ +40 <sup>(1)</sup>

<sup>(1)</sup> On request, also the “INOX” model can operate at this temperature.

### 3.9.4. PRESSER TECHNICAL FEATURES

Description		Value
Working pressure		6 (±1) bar (0.6±0.1 MPa)
Pneumatic cylinder with rod	H = 2200/2400 2800/3100	Air consumption 11 NI/min.



### 3.9.5. "MASTERPLAT PLUS TP3 FRD" AND "PGS" SPOOL CHARACTERISTICS

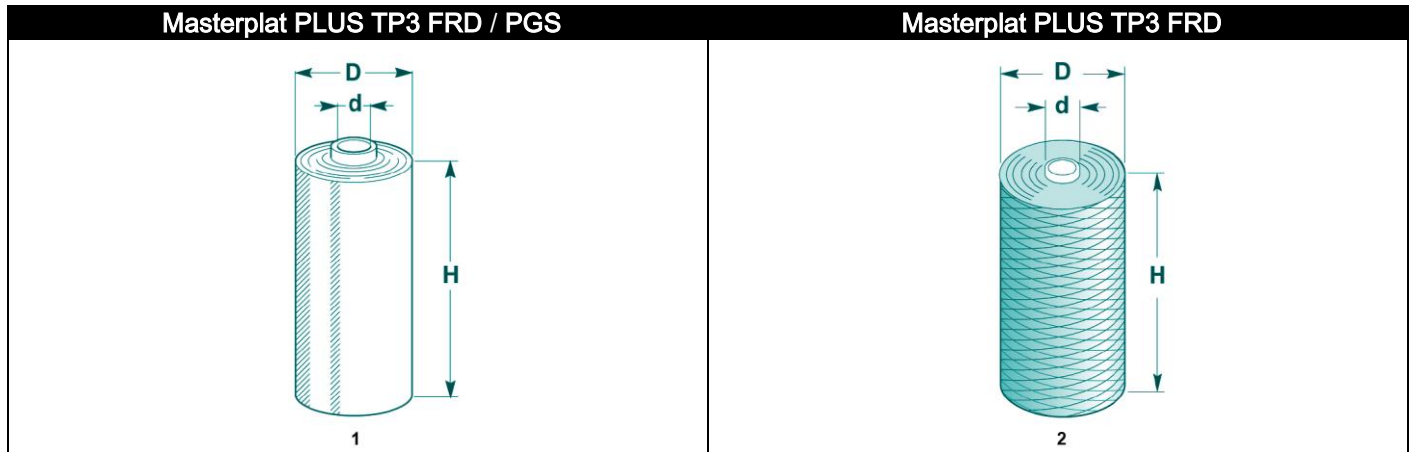

Description	Unit of measurement	Value
<b>Film spool dimensions (1)</b>		
Maximum outer diameter (D)	mm	300
Spool height (H)	mm	500
Film thickness	µm	17÷35
Internal diameter (d)	mm	76
Max. weight	kg	20
<b>Mesh spool dimensions (2)</b>		
Maximum outer diameter (D)	mm	300
Spool height (H)	mm	500
Internal diameter (d)	mm	76
Max. weight	kg	20

### 3.10. NOISE LEVEL

The values relating to airborne noise have been detected in compliance with standards:

- ISO 4871
- ISO 11201

Description	A-weighted emission sound pressure measured level at the operator's position (LpA)
Operation in working conditions.	69.3 dB (A)



**Caution - warning**

Prolonged exposure above **80 dB (A)** can be harmful.



The use of appropriate protection systems is recommended (earmuffs, ear plugs, etc.).

### 3.11. INSTALLATION ENVIRONMENT CHARACTERISTICS

The place where the machine is to be installed must be carefully selected taking into account the environment conditions in order to have correct and risk-free operating conditions.

Therefore we suggest to take into account the following prerequisites:

- An appropriate ambient temperature (see "Technical data").
- A perimeter area that must be left around the immediate working area, also for safety reasons (see "Perimeter areas").
- A flat surface, steady and without vibrations with adequate load bearing capacity, considering also the weight of palletised loads.
- The area must feature suitable sockets for compressed air and power distribution.



**Danger - warning**

Using this machine in explosive environments or when exposed to atmospheric agents is strictly forbidden.

## 4. INFORMATION ON HANDLING AND INSTALLATION

### 4.1. RECOMMENDATIONS FOR HANDLING AND LOADING

- Before performing any operation, the authorised operator must make sure to have understood the "Instructions for use".
- Carefully read the "Instructions for use" specified in the manual and those applied directly to the machine and/or the package.
- Provide suitable safety conditions in compliance with the regulations on workplace safety to prevent and minimise the risks.
- Pay attention to the safety warnings, do not misuse the machine and assess the possible residual risks.

### 4.2. PACKING AND UNPACKING

The packing is realised, keeping the overall dimensions limited, also in consideration of the transport chosen.

To facilitate transport, shipping can be performed with some components disassembled and appropriately protected and packaged.

Some parts, especially electrical equipment, are protected with anti-moisture nylon covers.

The packages bear all necessary information for loading and unloading.

When unpacking, check the integrity and exact quantity of the components.

Packaging material should be appropriately disposed of according to the laws in force.

The illustrations show the common types of packaging used.

**Package on pallet with nylon protection**

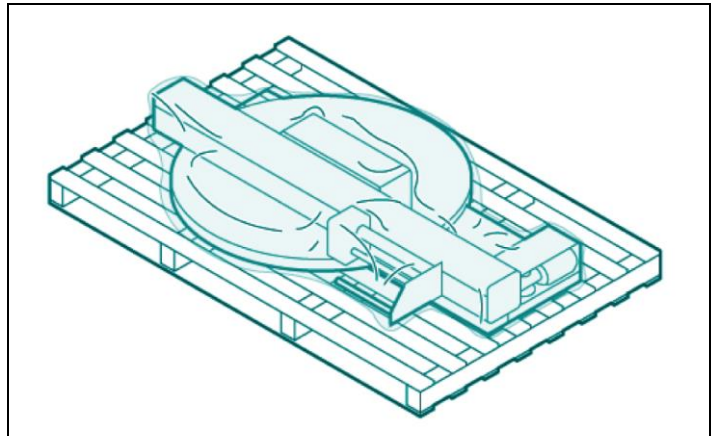

**Package in crate**

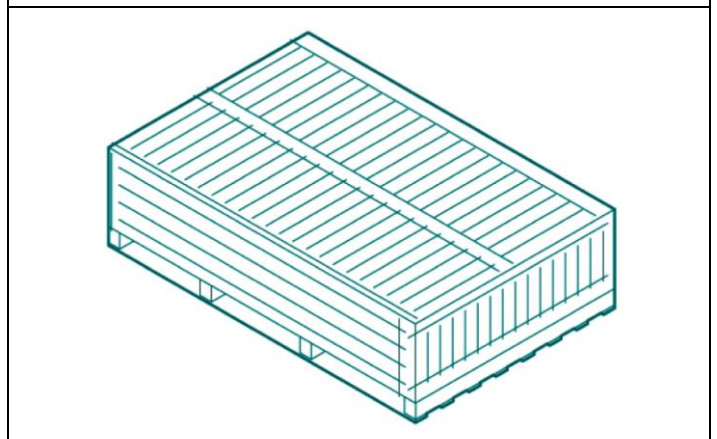

Package with cardboard box

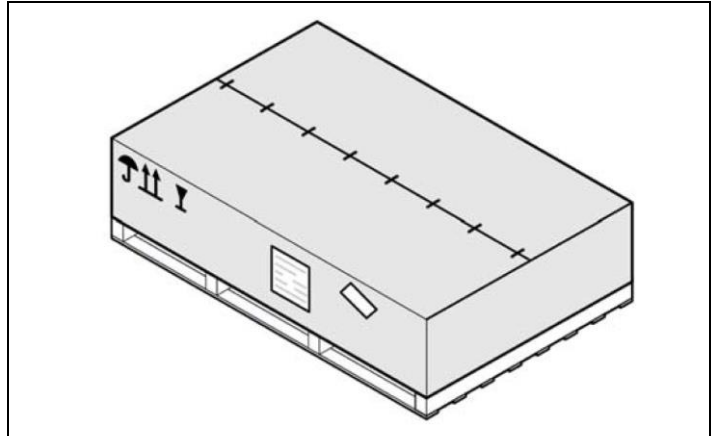

Package in cage

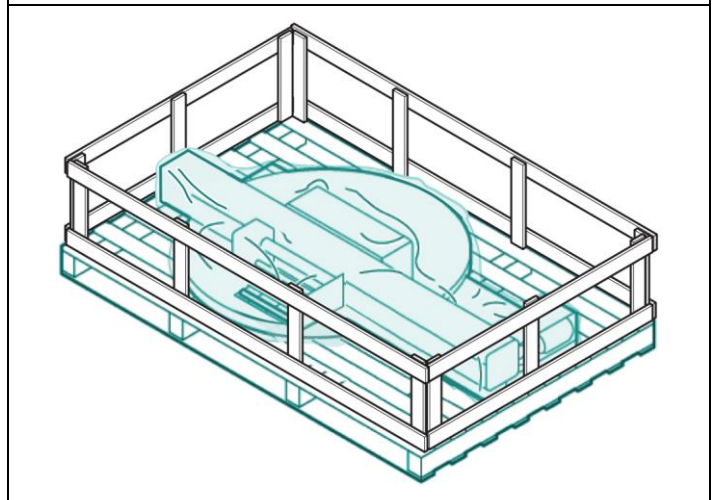

Package in cage (Masterplat PLUS LP)

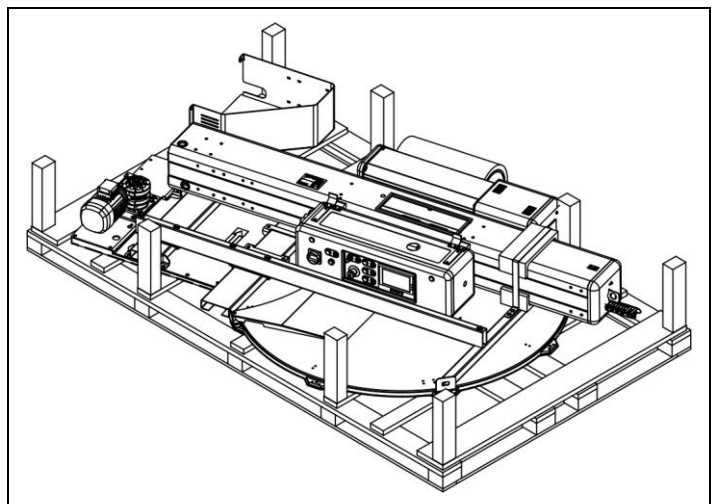

### 4.3. TRANSPORT AND HANDLING

Transport, also according to the destination, can be performed with different vehicles.

The diagram represents the most used solutions.

During transport, in order to avoid sudden movements, adequately anchor the machine to the vehicle.



**Important**

For further transportations, recreate the initial packaging conditions for transport and handling.

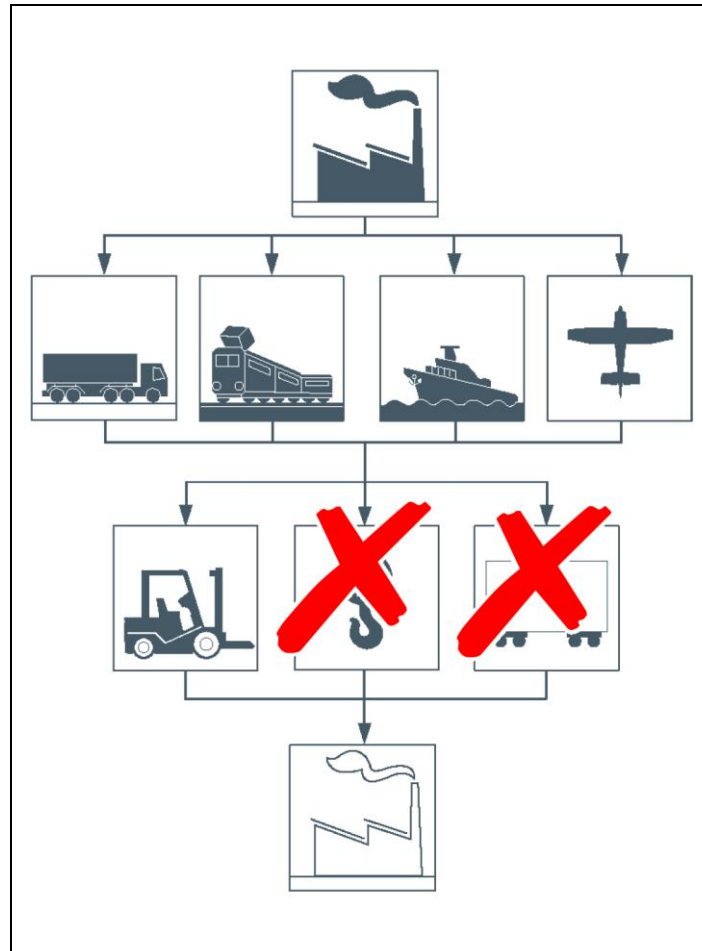

#### 4.4. HANDLING AND LIFTING

The machine can be moved with a forklift truck with suitable load capacity by inserting the forks in the points indicated directly on the machine.

Transport and lifting means must be operated by personnel authorised and qualified for the use of such means.

**Masterplat PLUS**

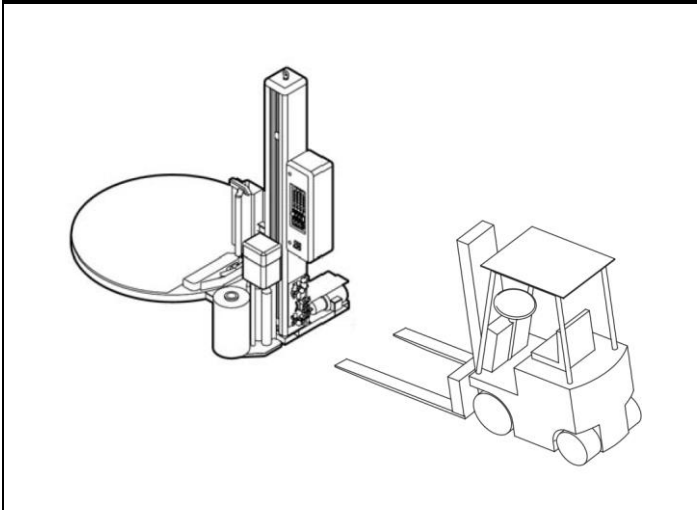

**Masterplat PLUS TP3**

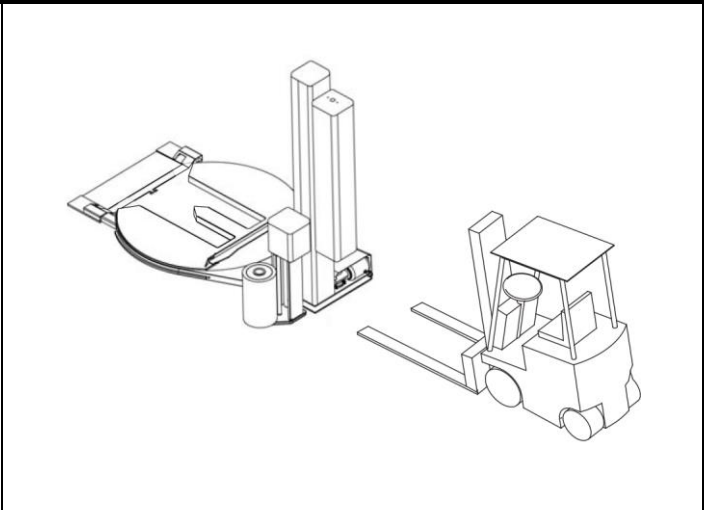

**Masterplat PLUS LP**

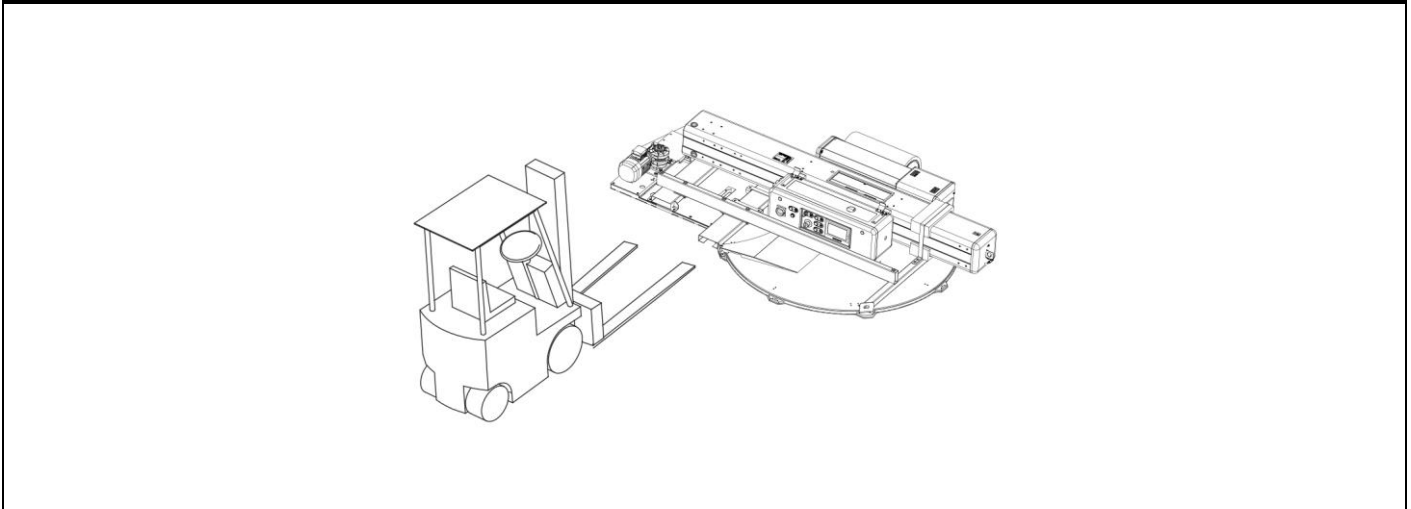

#### 4.5. INSTALLATION OF THE MACHINE

The machine must be installed in an area which fulfils the requirements indicated in paragraph "Installation environment characteristics".

If necessary, identify the exact position by plotting the coordinates for correct positioning.



**Danger - warning**

Authorised technical service personnel must perform installation and assembly operations.

Proceed as follows:

1. Insert the forklift truck forks in the specially designed spaces provided in the base.
2. Lift the machine from the pallet (if any).



**Danger - warning**

To perform the operation in safety conditions, insert some wooden blocks under the forks of the forklift truck and place everything on the floor.

3. Place the machine in the area assigned for assembly.



**Important**

The resting surface must be smooth and well levelled.

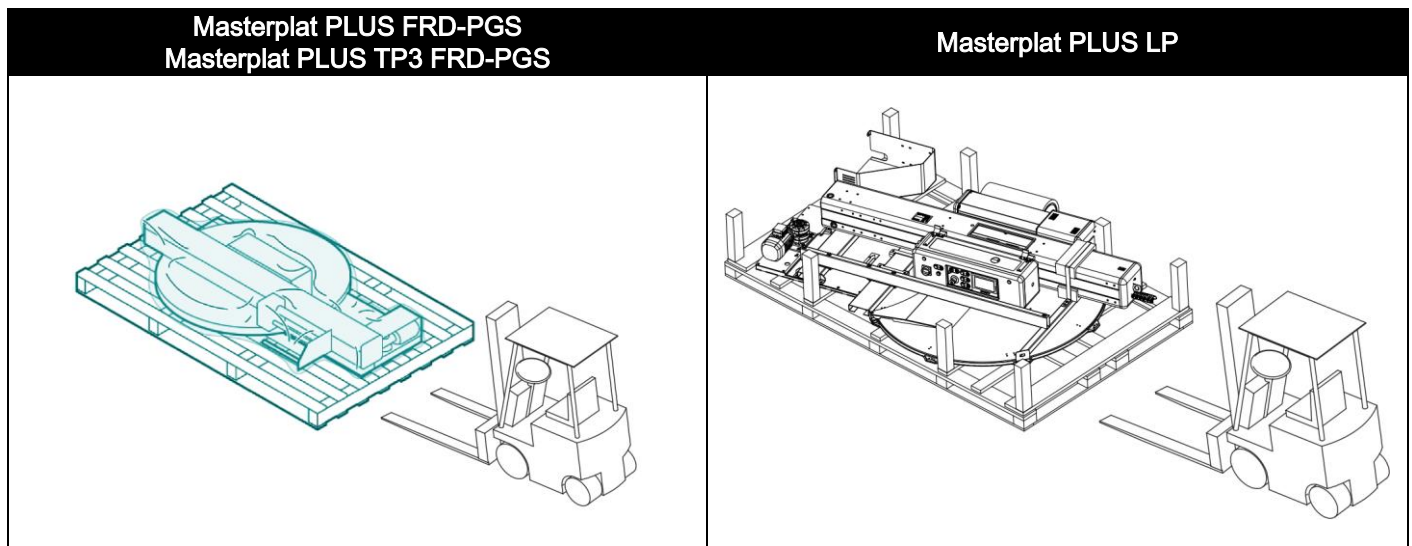

#### 4.5.1. ELECTRIC BOX ASSEMBLY

1. Cut the tie (A) which gathers the electric cables.
2. Remove the mounting brackets (B).
3. Route the electric cables (C) inside the slide shaft.
4. Lift the electric box (D).
5. Fasten the electric box to the slide shaft with the screws (E).
6. Close the cover (F) of the electric box (D) with the suitable key (G).

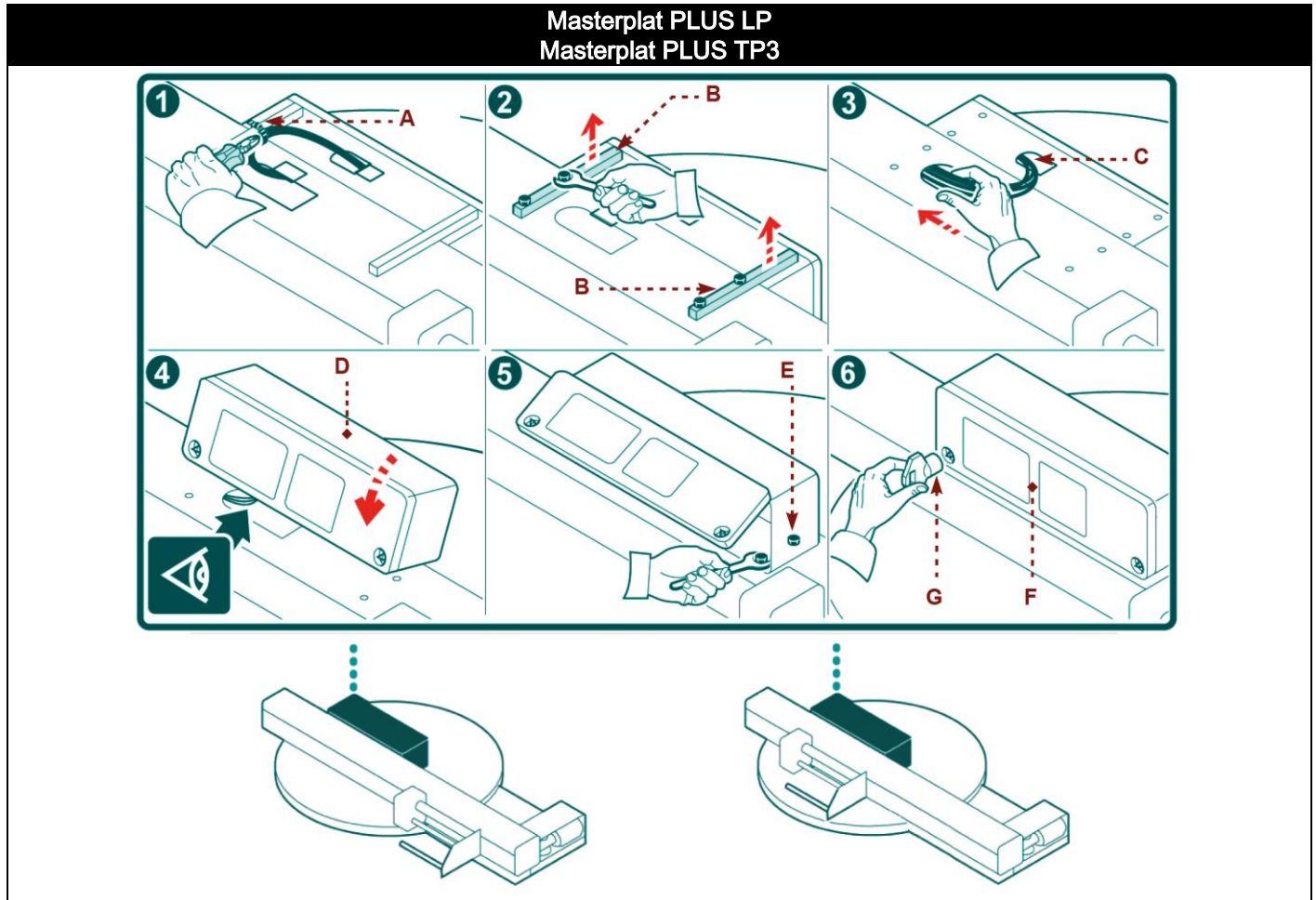



#### 4.5.2. SLIDE SHAFT ASSEMBLY

1. In certain configurations it is necessary to lift and position the slide shaft (H) above the rotary table, in correspondence with the hinge.
2. Insert the screws (L) into the hinge without tightening them.

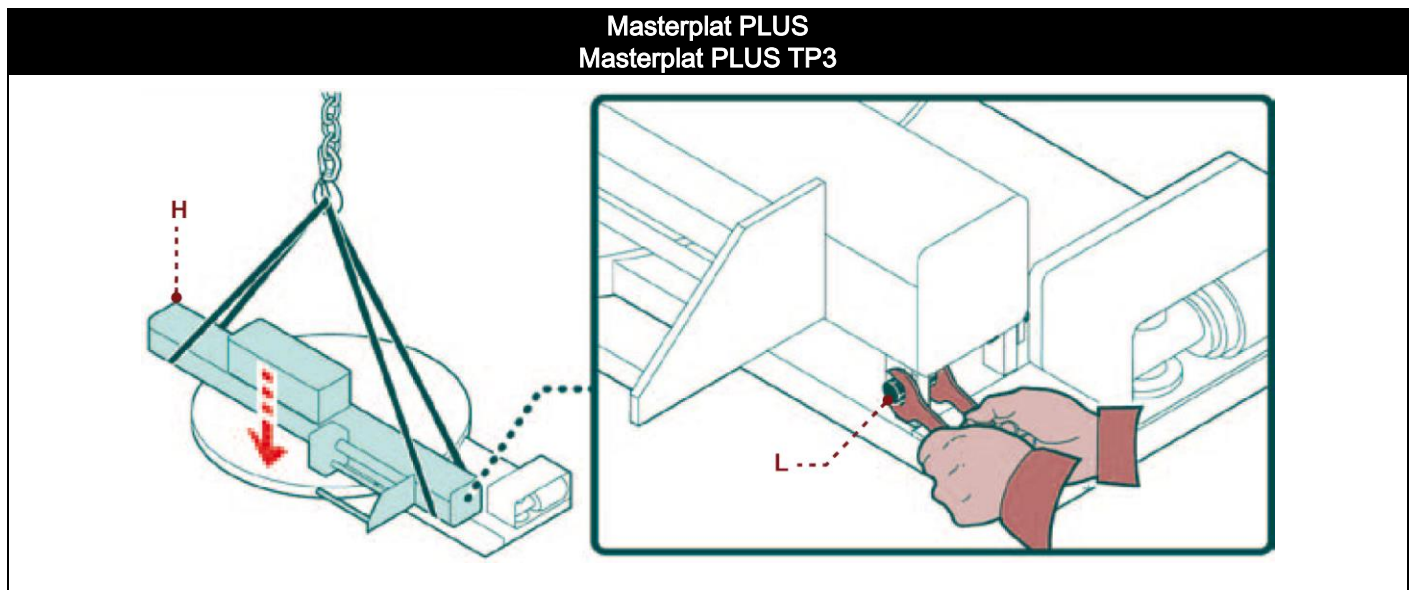

3. Connect the lifting device hook in the bracket (M) of the slide shaft and tension.
4. Lift the slide shaft (H).
5. Fasten the slide shaft to the machine body with the screws (N).
6. Tighten the screws of the hinge (L).

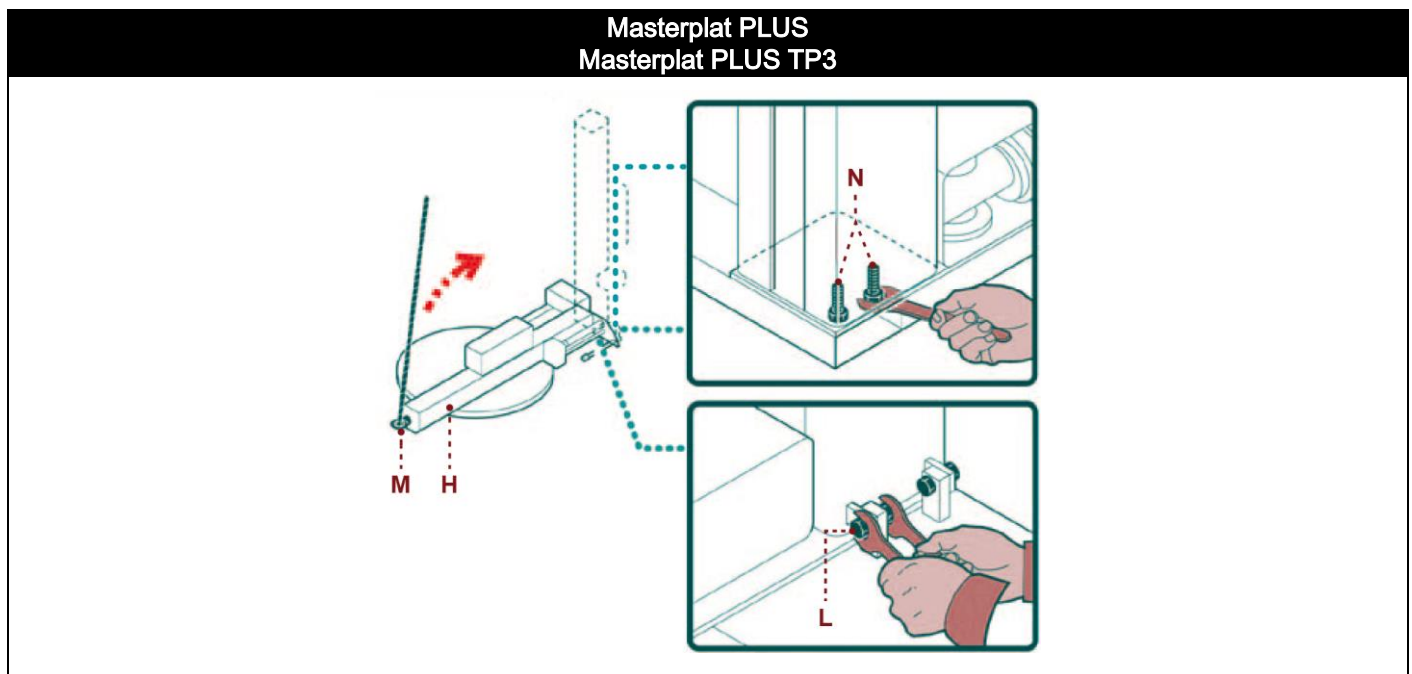

### 4.5.3. SLIDE SHAFT ASSEMBLY

1. Loosen the screws (A).
2. Lift the latch of the slide shaft (B).
3. Connect the hook of the lifting device to the bracket (C) of the slide shaft and tension (Only for slide shaft with a height of 2200-2400 mm).
4. Lift the slide shaft (D).
5. Fasten the slide shaft to the machine body with the screws (E).
6. Tighten the screws of the hinge (F).

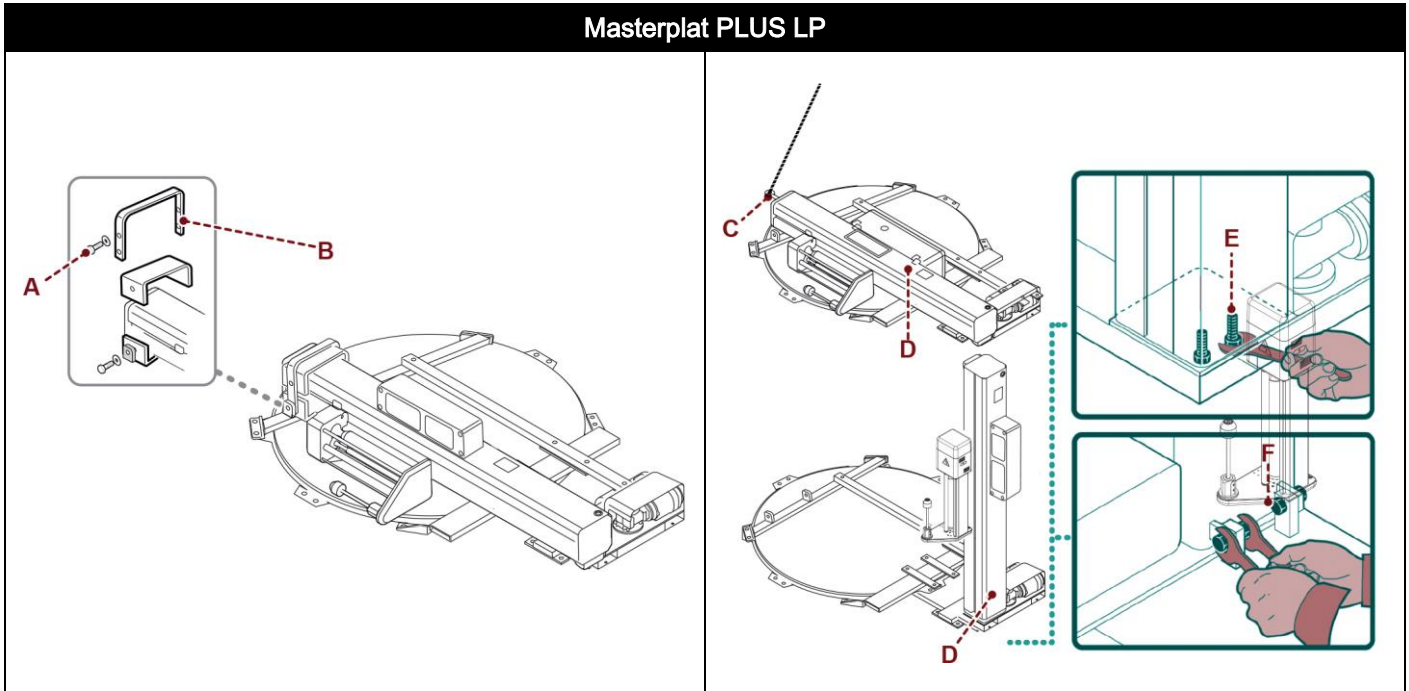

7. Loosen the screws (G).
8. Remove the bracket (H).

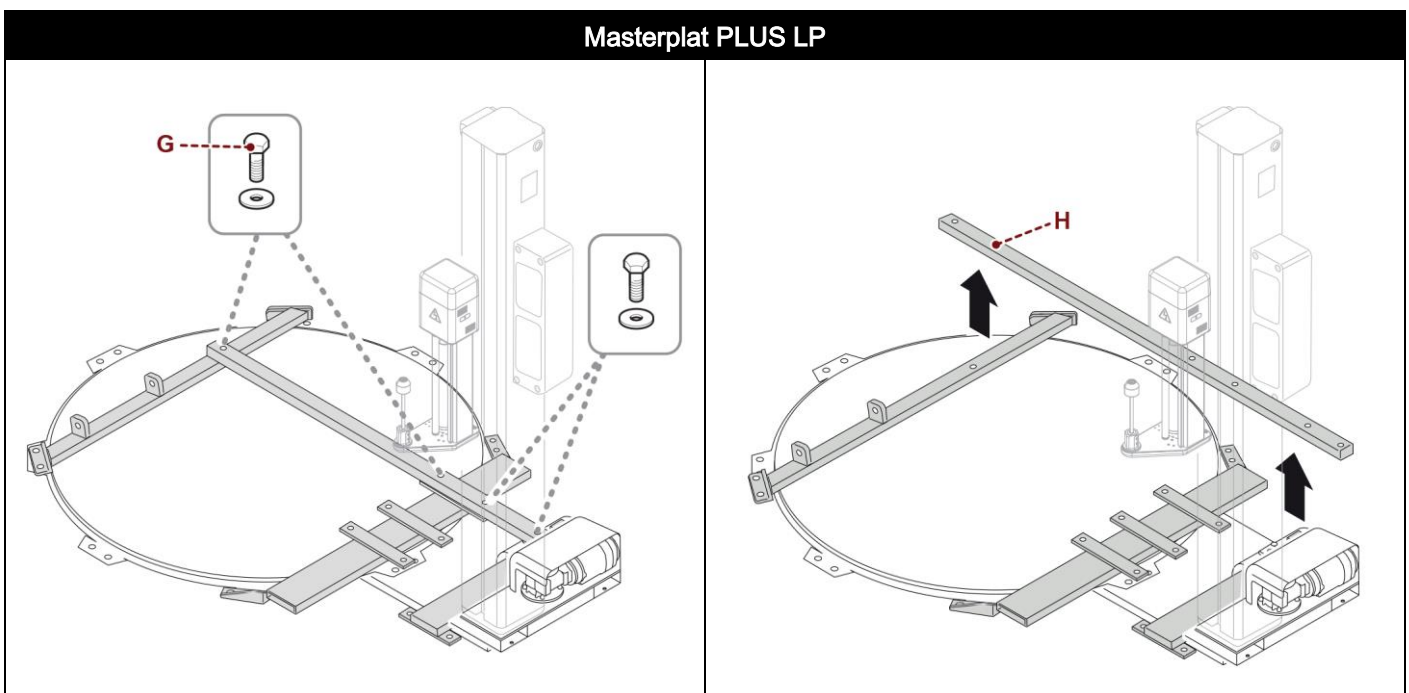

9. Loosen the screws (L) and remove the brackets (M).

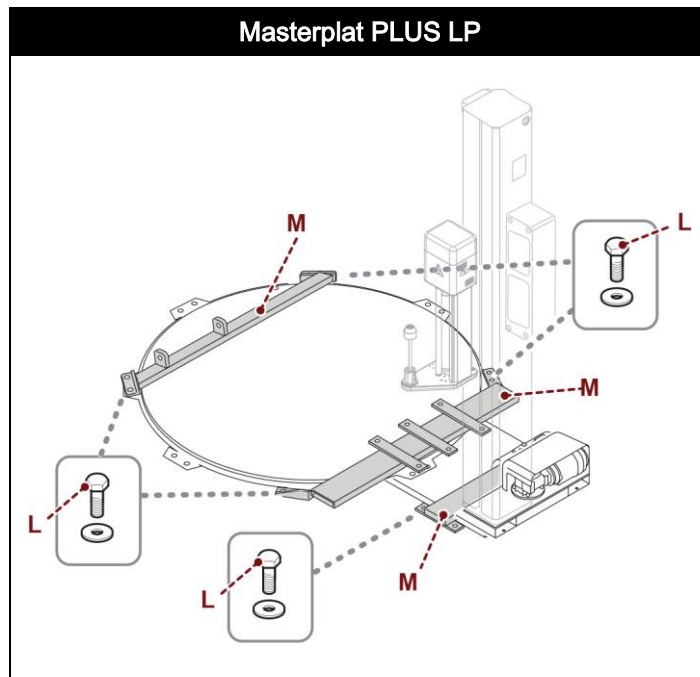

#### 4.5.4. LOADING/UNLOADING RAMP ASSEMBLY

Assemble the pallet loading/unloading ramp (Y) and connect the power connector (Z).

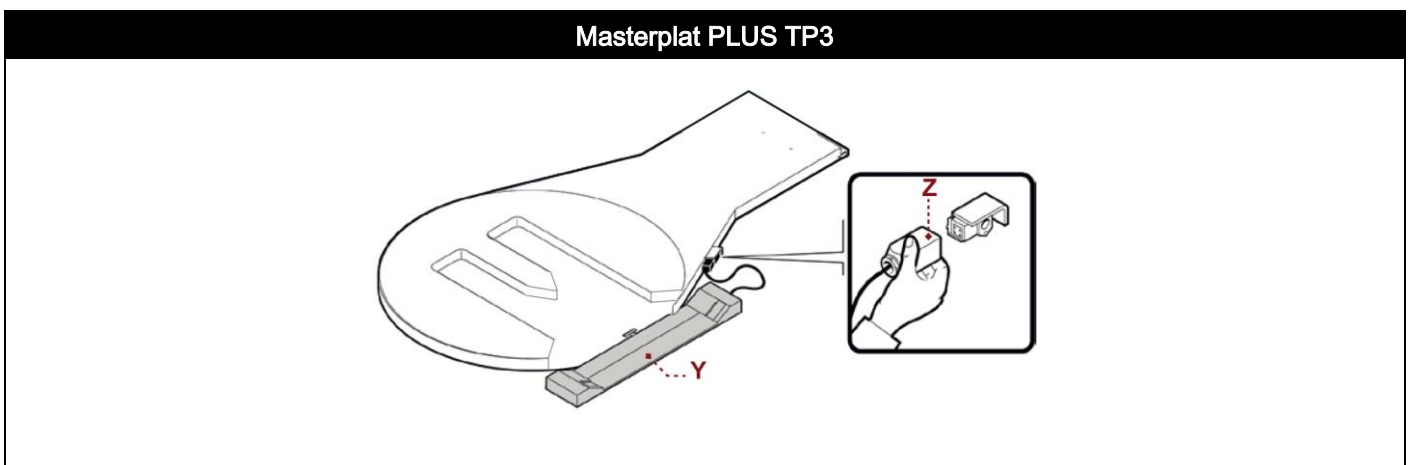

#### 4.5.4.1. LOADING DIRECTION MODIFICATION

- A. Remove the chain cover base (1) by loosening the fastening screws (2).  
Remove the guards (3) and (4) that cover the loading ramp photocell, by loosening the fastening screws (5).
- B. Disconnect the cable of photocell (6) and (7), for the emitter and the receiver.

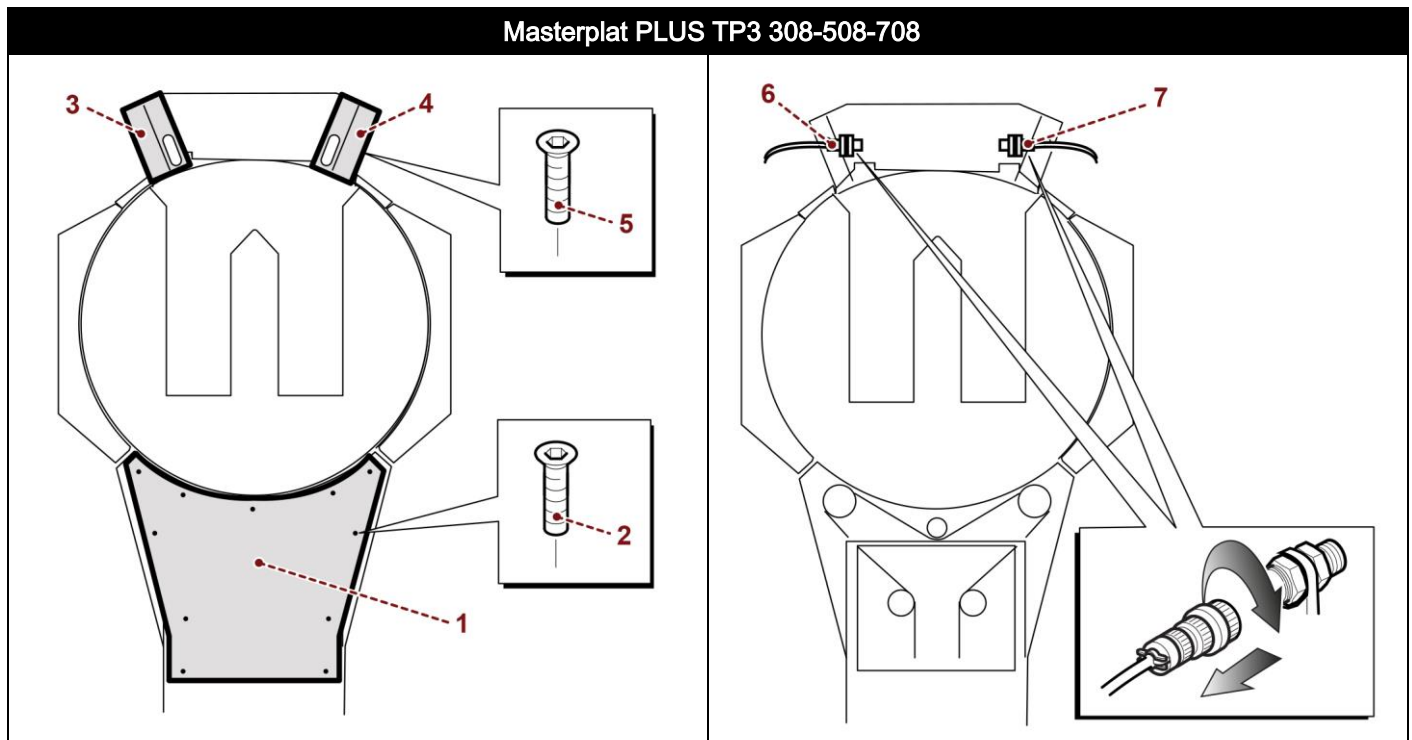

- C. Insert the supporting knobs (8) and move the upstroke ramp (9).
- D. Remove one of the two upper LH (10) or RH (11) guards and one of the two upper connection guards (12) or (13), by loosening the fastening screws (14).

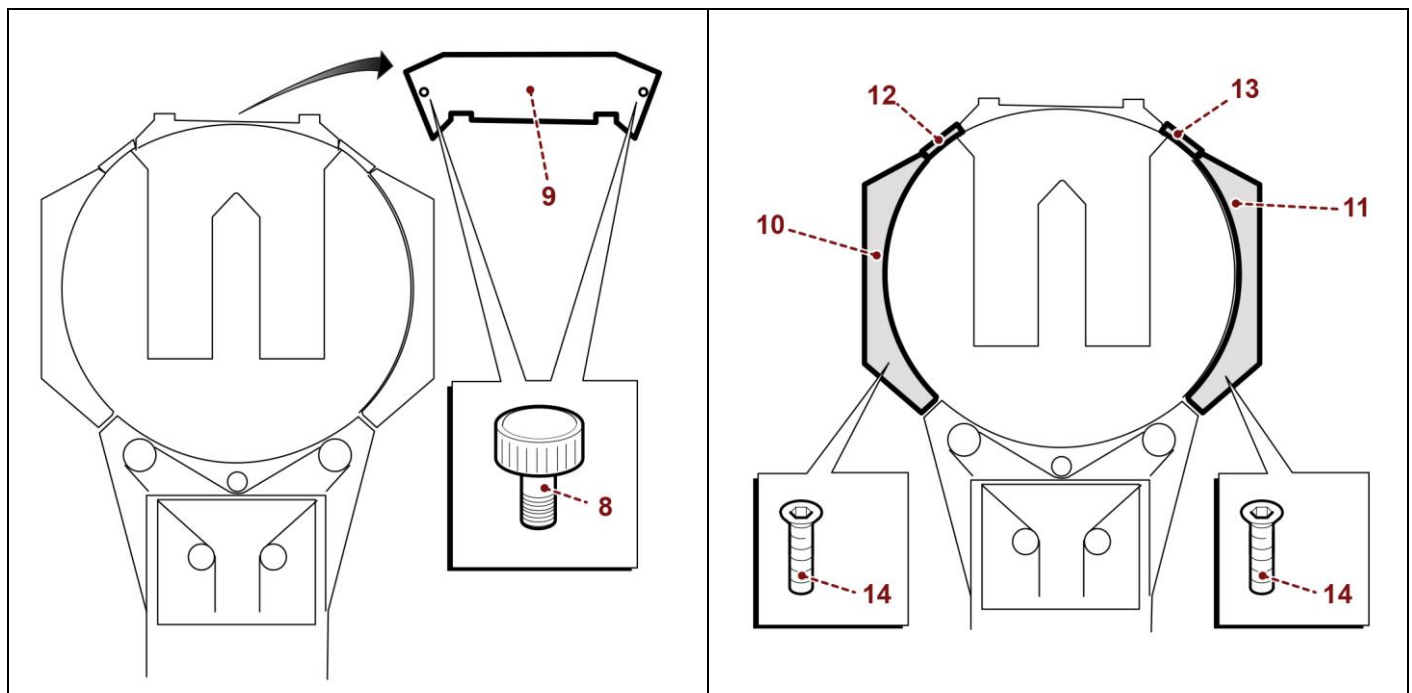

- E. Remove the connector cable (6) from the chosen side (in this case, LH 10) and from the connection guards (12).
- F. Slide the photocell receiver connector cable (16) out from the opposite side of the ramp position.

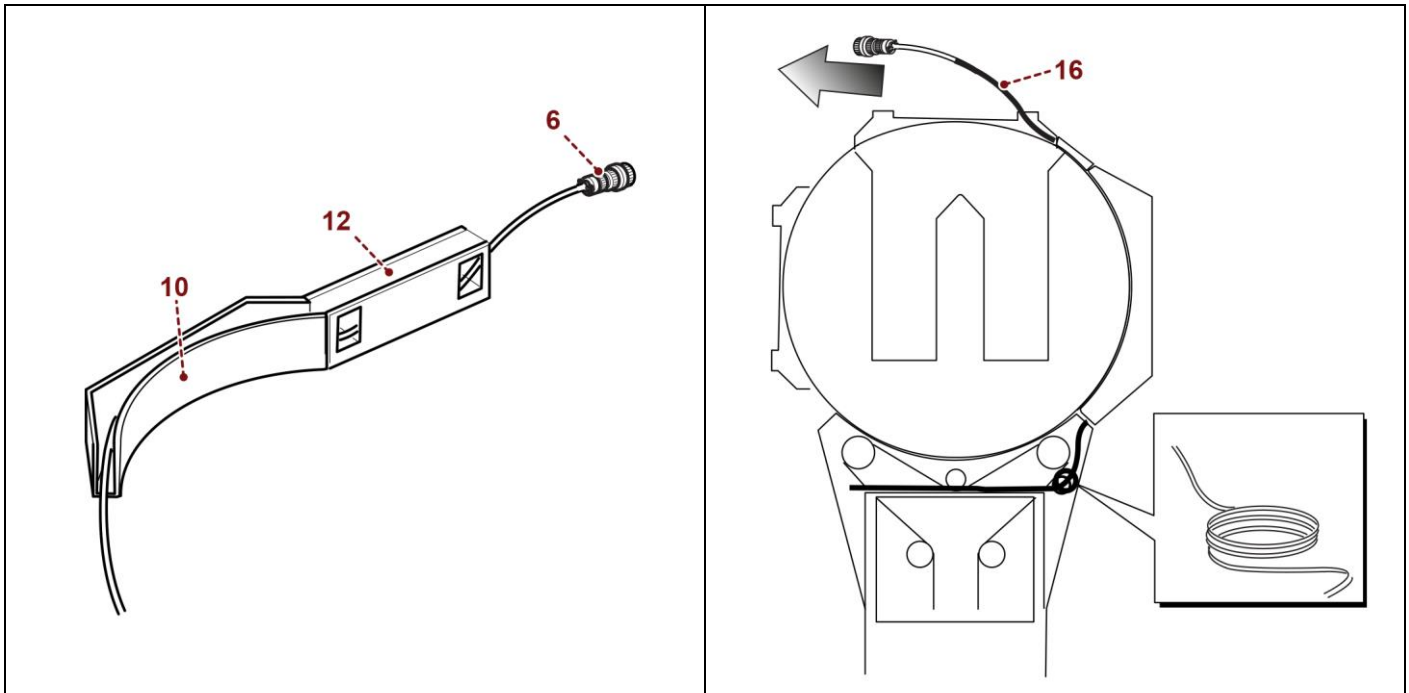

- G. Remove the guard (10) from the initial position and reposition it on the front side, fastening it with the screws (14).
- H. Reposition the photocell receiver connector cable (16) in the guard (10) and in the connection guard (12).

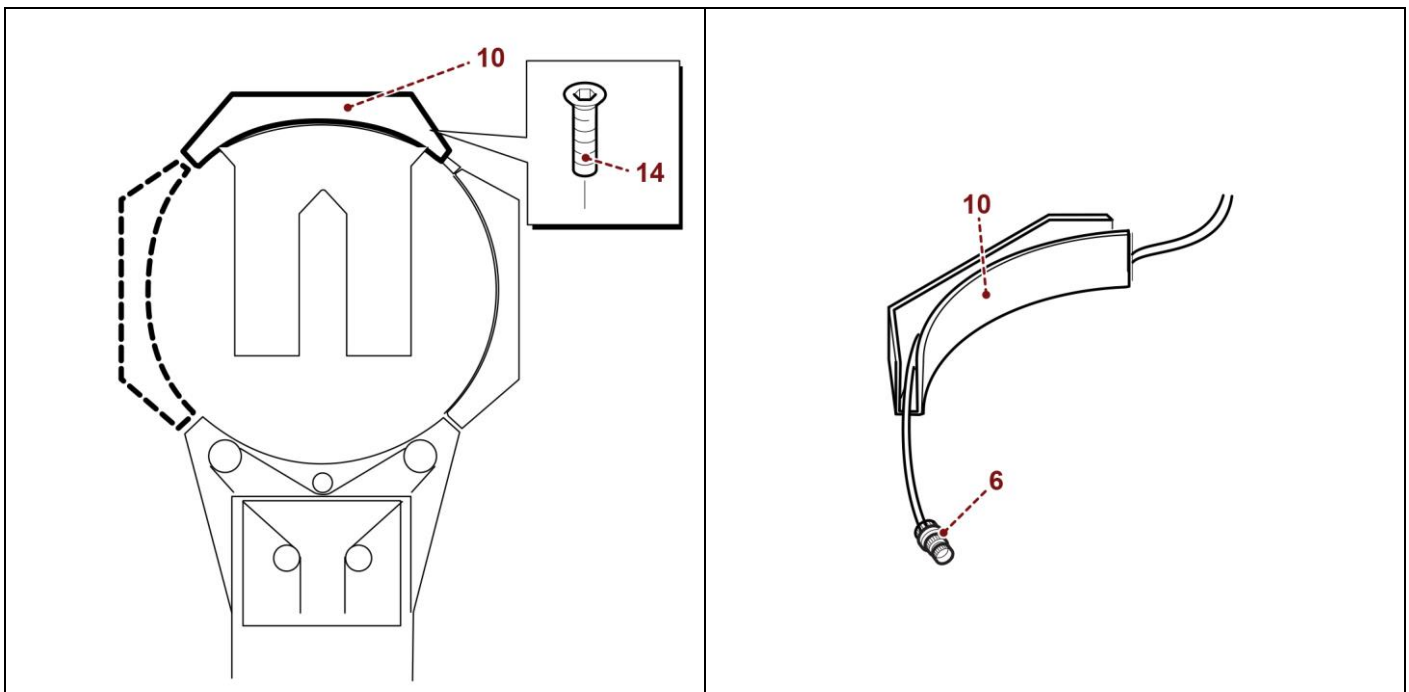

- I. Fasten the connection guard (12) with the screws (14) and insert the cable inside it.
- J. Refit the upper guard (10) and the upper connection guard (12) with the fastening screws (14).

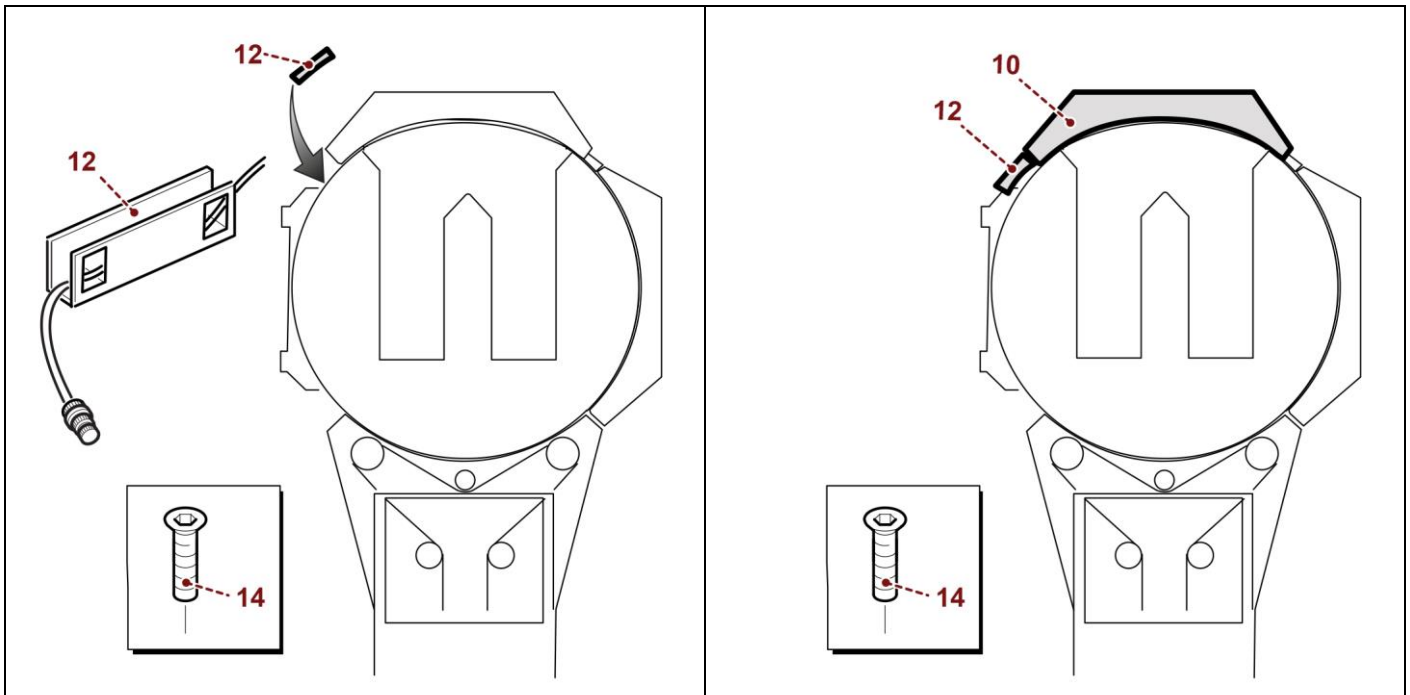

- K. Position the upstroke ramp (9) on the side and screw the supporting knobs (8).
- L. Recover the cable in excess (16-17) using a tie, connect the connector (6-7) to the photocell receiver and position the photocell guard (3).

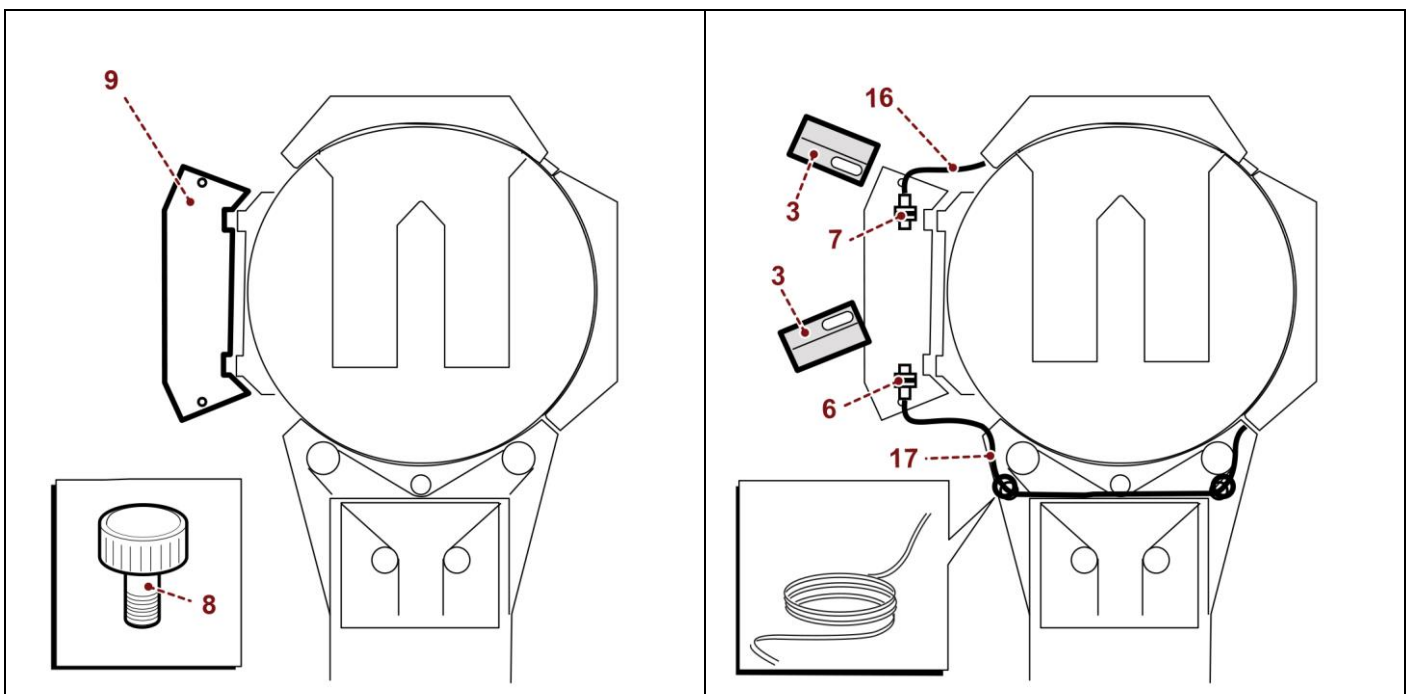

- M. Refit the guard (1) that covers the base.
- N. Unscrew the reflector (18).

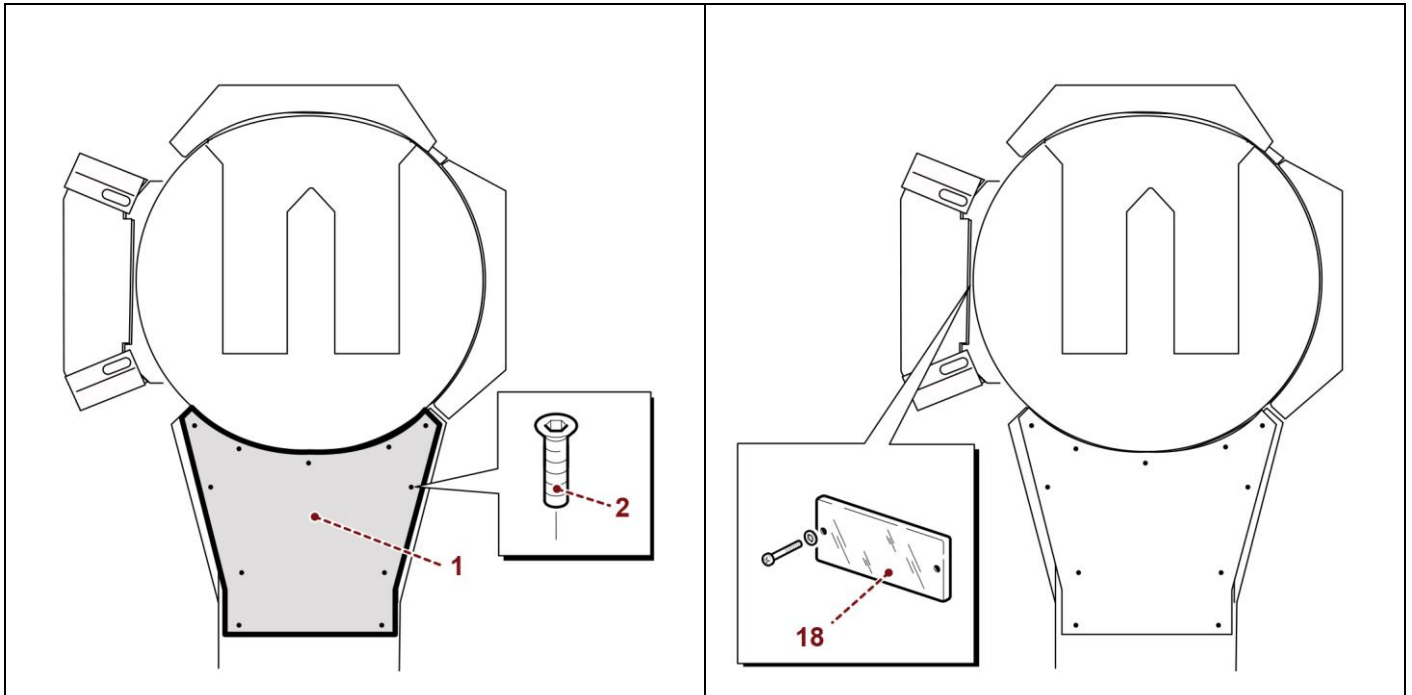

- O. Turn the plate clockwise until the reflector (18) is positioned on the opposite side of the loading area.
- P. Press the "Home position" button to turn the plate clockwise and position it in the loading point.

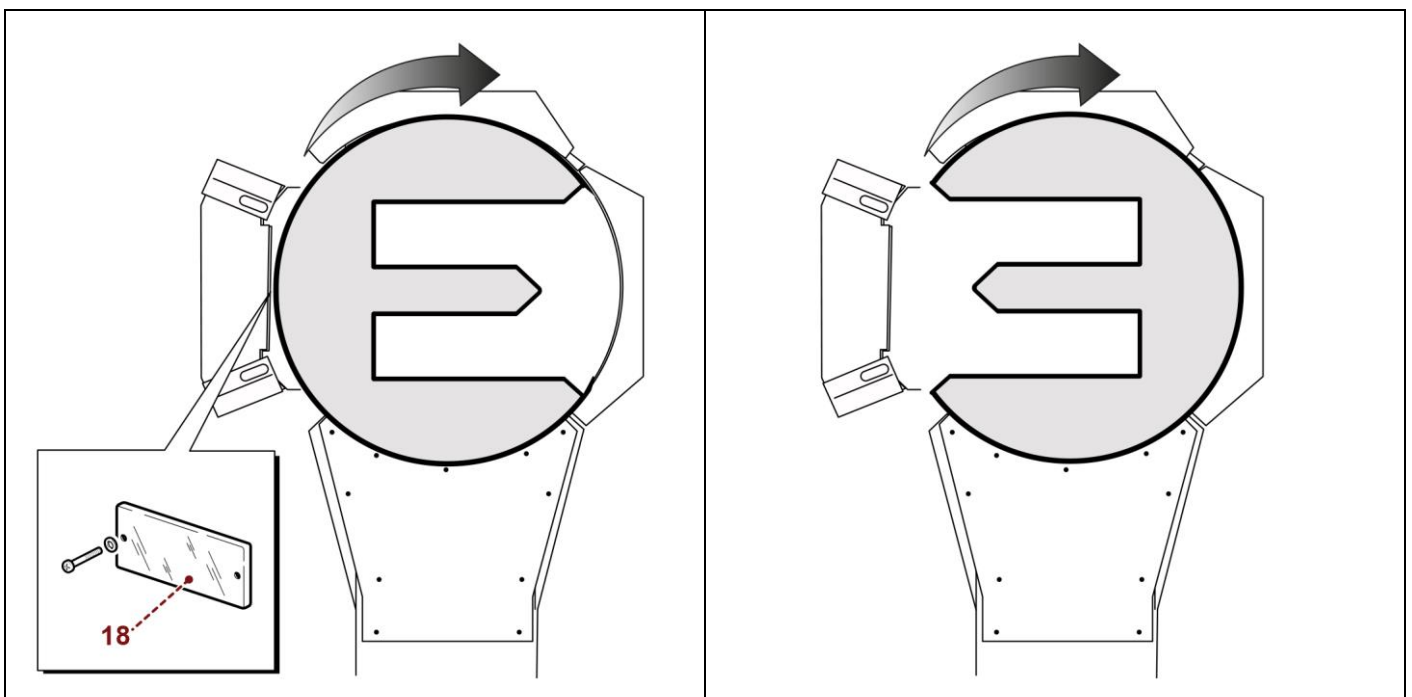

#### 4.5.5. PNEUMATIC PRESSER ASSEMBLY (OPTIONAL)

1. Fasten the guide (P) to the slide shaft with the suitable screws (Q).
2. Fit the arm (R) on the guide and fasten it with the screws (S).
3. Fit the presser plate (T) on the arm.



**Important**

The pneumatic connections have already been performed by the Manufacturer if the presser is delivered with the machine.

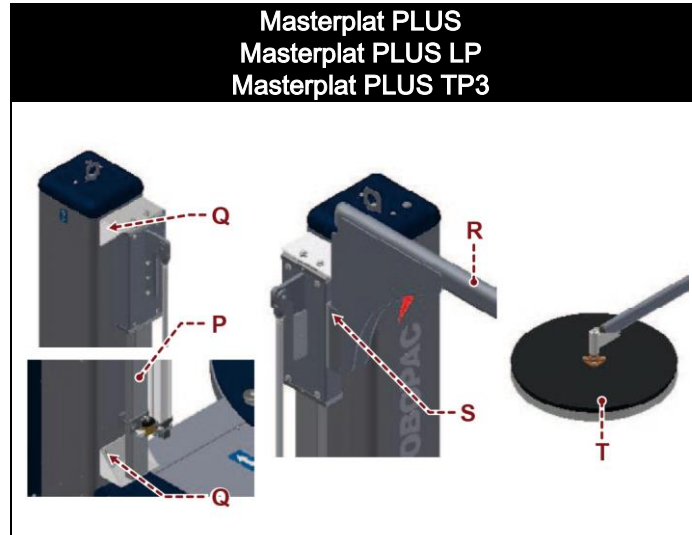



#### 4.6. MACHINE FIXING

Once the units have been assembled and levels, squaring, parallelism and orthogonality have been checked, it is necessary to fix the machine body to the floor.

Depending on the floor type, it may be necessary, before laying the machine, to lay foundations in correspondence of the various supporting legs.

Laying the foundations and fixing the machine is essential to ensuring the machine stability and functionality.



**Important**

Should it be necessary, insert metal plates (A) between the screws and the floor.

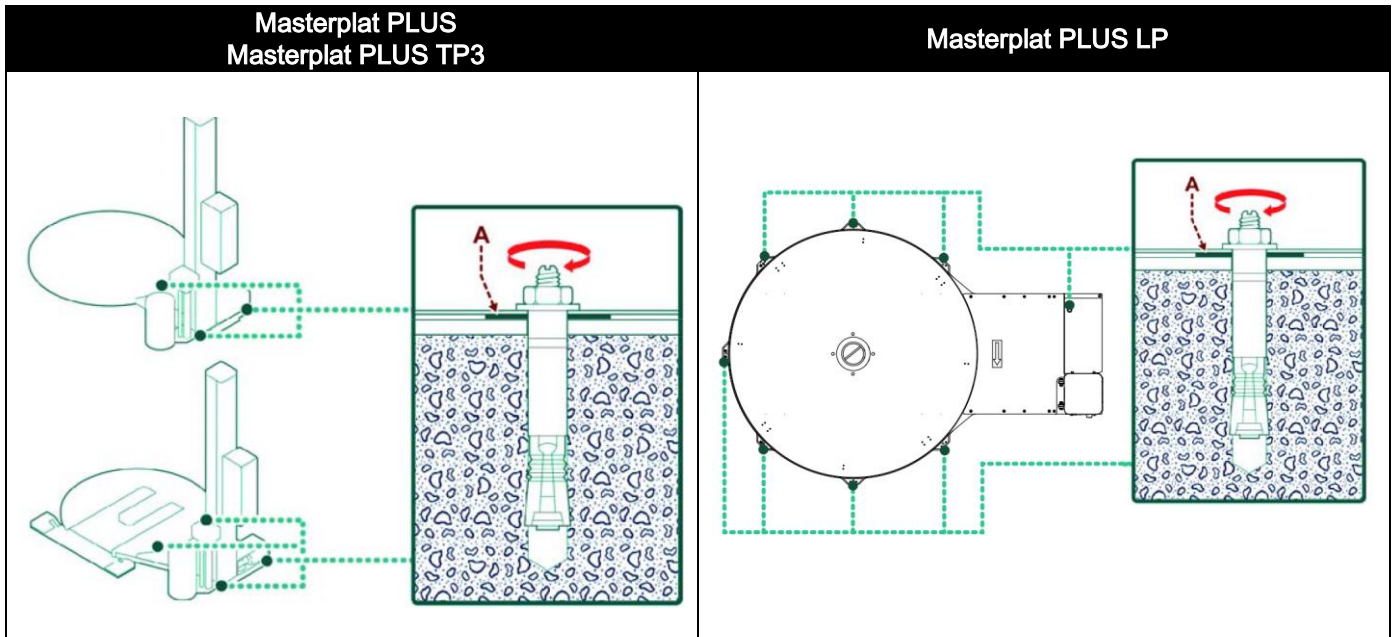

#### 4.7. MACHINE UNDERGROUND INSTALLATION

Dig a pitch in the floor to insert the template (C) and fix it with a concrete casting.

The template (C) is supplied on request (Optional).



**Important**

The depth (X) must be equal to the machine base height.

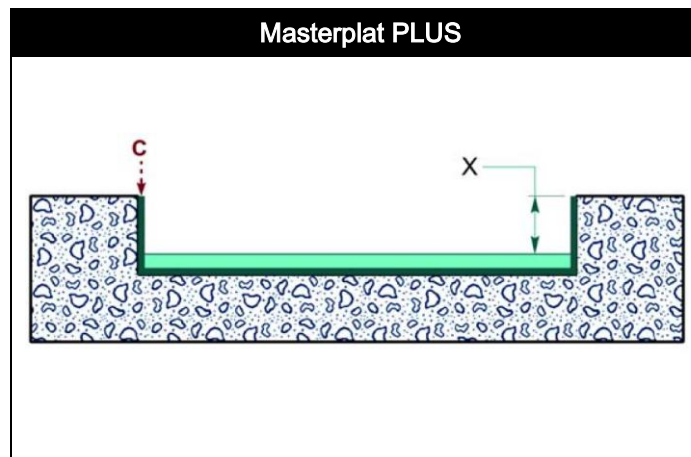

#### 4.8. RECOMMENDATIONS FOR CONNECTIONS



##### Important

The connections must be made in accordance with the specifications supplied by the Manufacturer in the enclosed diagrams. The person authorised to carry out said operation must have the skills and experience acquired and acknowledged in the specific sector, must perform the connection in accordance with the best practice and take into account all the regulatory and legislative requirements. Once the connection has been completed, before commissioning the machinery, it is necessary to perform an overall check to verify if said requirements have been complied with.

#### 4.9. PNEUMATIC CONNECTION

1. Insert a flexible hose in the end of the hose barb fitting and fasten it with a metallic screw clamp (A).
  2. Check that the valve (B) is in the "OPEN" position.
  3. Activate the supply line pressure.
  4. Check that the pressure gauge indicates at least **6 bar** and use the knob (C) to compensate any pressure difference.
- Repeat this operation when the machine is running.

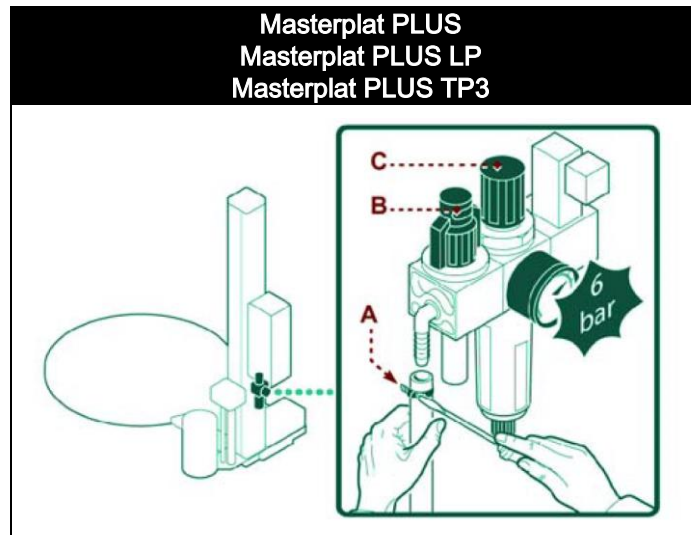

#### 4.10.ELECTRICAL CONNECTION

Proceed as follows for the electrical connection.

1. Check that the line voltage (V) and frequency (Hz) correspond to those of the machine (See identification plate and wiring diagram).
2. Turn main switch to pos. 0 (OFF).
3. Connect the power cable (if supplied) to the socket (A), as shown in the figure, in accordance with the mains supply.
4. The earth wire (yellow-green) must be connected to its earth terminal PE.
5. Power the machine using the main switch.
6. Press the "Reset" button.
7. When the "Start" button is pressed, the plate should turn anticlockwise.
8. Provided by the customer.

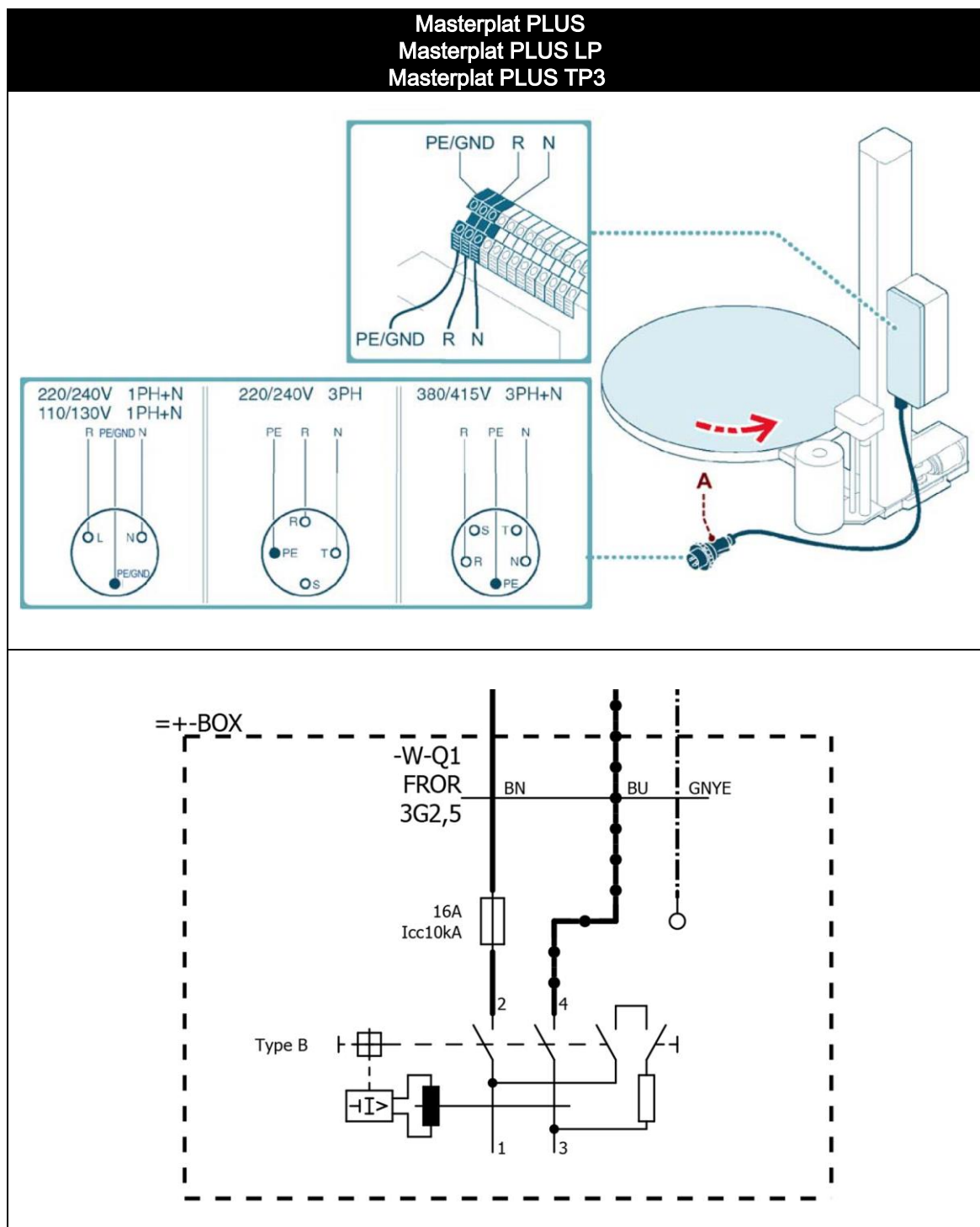

## 5. INFORMATION ON ADJUSTMENTS

### 5.1. RECOMMENDATIONS FOR ADJUSTMENTS

- Before performing any operation, the authorised operator must make sure to have understood the "Instructions for use".
- Activate all the safety devices provided, stop the machine and assess whether there is any residual energy before carrying out the operations.
- Provide suitable safety conditions in compliance with the regulations on workplace safety to prevent and minimise the risks.
- Pay attention to the safety warnings, do not misuse the machine and assess the possible residual risks.

### 5.2. "FILM STRETCH" ADJUSTMENT

#### 5.2.1. SPOOL CARRIAGES OF "FRD" TYPE

1. Use the lever (A) to lock and unlock the roller (B).
2. Use the handwheel (C) to adjust the braking action of the stretching roller (B) which determines the film stretch.

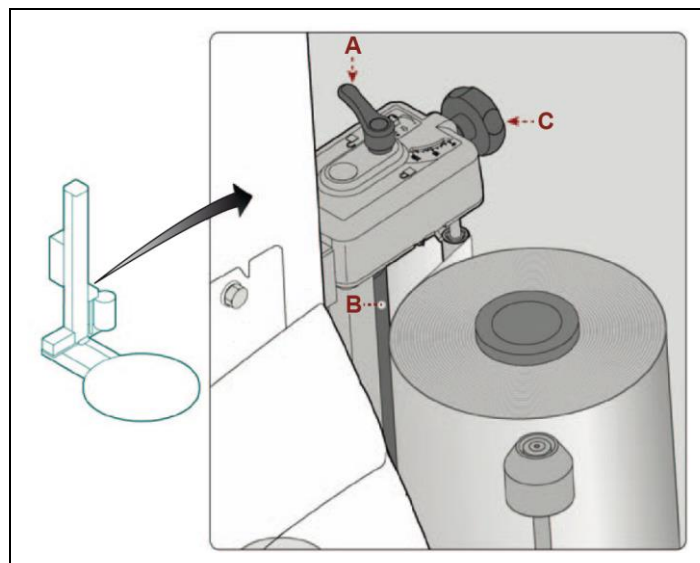

### 5.2.2. SPOOL CARRIAGES OF "PGS" TYPE (PRE-STRETCH GEAR REPLACEMENT)

1. Stop the machine in safety conditions.
2. Remove the guard (A).
3. Slacken the belt (C) using the tensioner (B).
4. Slide the belt out of the pulley (D).
5. Loosen the screws (E).
6. Remove the plate (F) with motor and bearings.

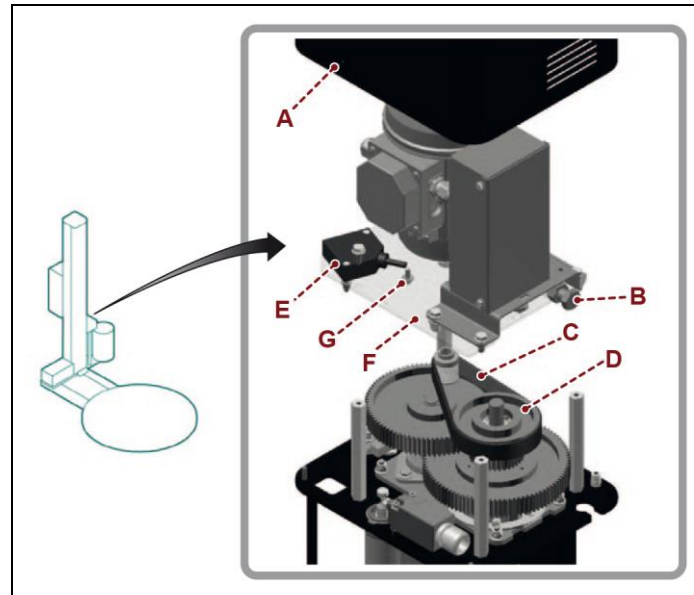

7. Remove the retaining ring (G).
8. Remove the pulley (D).
9. Remove the retaining ring (H).
10. Remove the gear (L).
11. Remove the retaining ring (M).
12. Remove the gear (N).
13. Loosen the screws and remove the disc (P) from the gear (N).
14. Select the set of gears (L-N) relating to the concerned pre-stretch rate (see table).

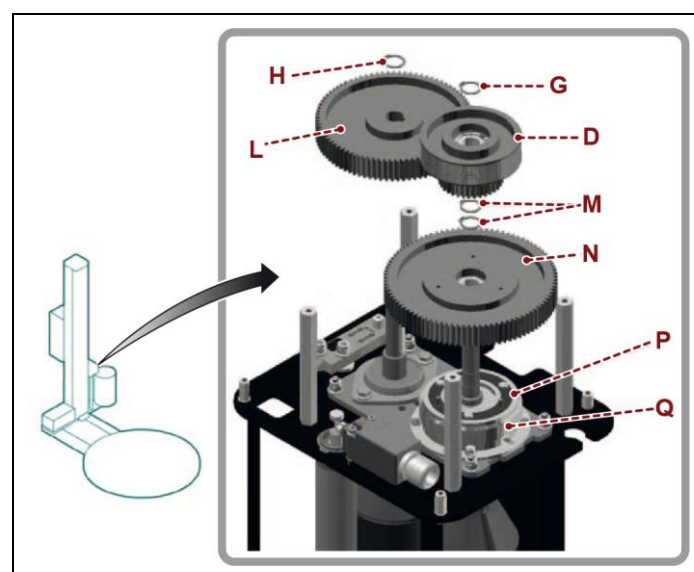

The table indicates the pre-stretch values which can be obtained with the relevant transmission gear set.



**Important**

Set the pre-stretch according to the film resistance and quality in order to obtain a low consumption.

Pre-stretch percentage	Gear code (L)	No. of gear teeth (L)	Gear code (N)	No. of gear teeth (N)
150%	2540300068	34	2540300070	85
200%	2540300003	29	2540300002	90
250%	2540300165	25	2540300164	94
300%	2540300027	24	2540300028	95

15. Correctly fix the spacer (P) to the gear (N) of the new transmission gear set.
16. Fit the gear (N) of the new transmission gear set.
17. Position the gear with the spacer (P) facing the carriage.
18. Fit the retaining ring (M).
19. Fit the gear (L) of the new transmission gear set.
20. Fit the retaining ring (H).
21. Fit the pulley (D).
22. Fit the retaining ring (G).



**Important**

During reassembly, make sure that coupling tabs are correctly engaged.

23. Rest the plate (F) on the stud bolts, paying attention to fit the belt (C) on the pulley (D).
24. Tighten the screws (E).
25. Tension the belt (C) using the tensioner (B).
26. Manually turn the pre-stretching rollers in both directions to correctly seat the coupling between belt and pulleys.
27. Check the belt tensioning again and properly adjust it if necessary.
28. Refit the guard (A) when finished.

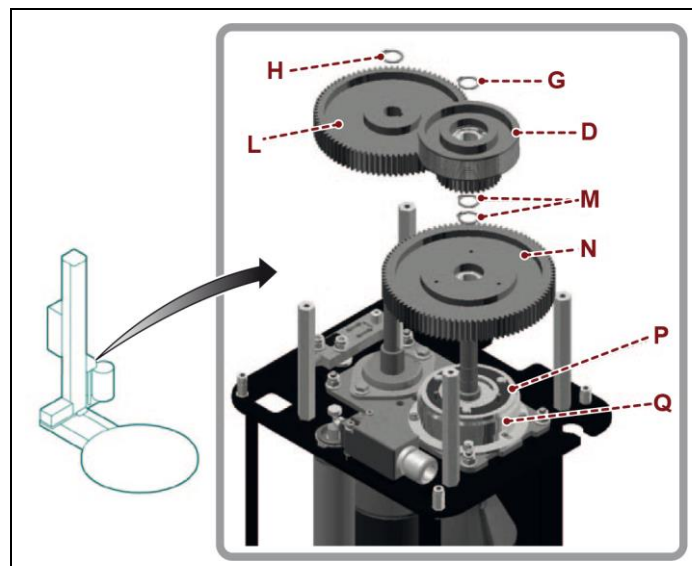

### 5.2.3. SPOOL CARRIAGES OF "FRD for mesh" TYPE

1. Work on the handwheel (C) until reaching the value displayed on the index (E).

The brake shaft for mesh is an accessory that can be mounted on the carriage later on. This optional allows the system to use a mesh spool with an "FRD" std carriage.



**Important**

For a correct tensioning of the mesh, adjust the braking effect so that the outfeed roller (G) is more braked than the infeed roller (H); moreover, it is necessary to avoid braking the stretching rollers too much to prevent the mesh from slipping.

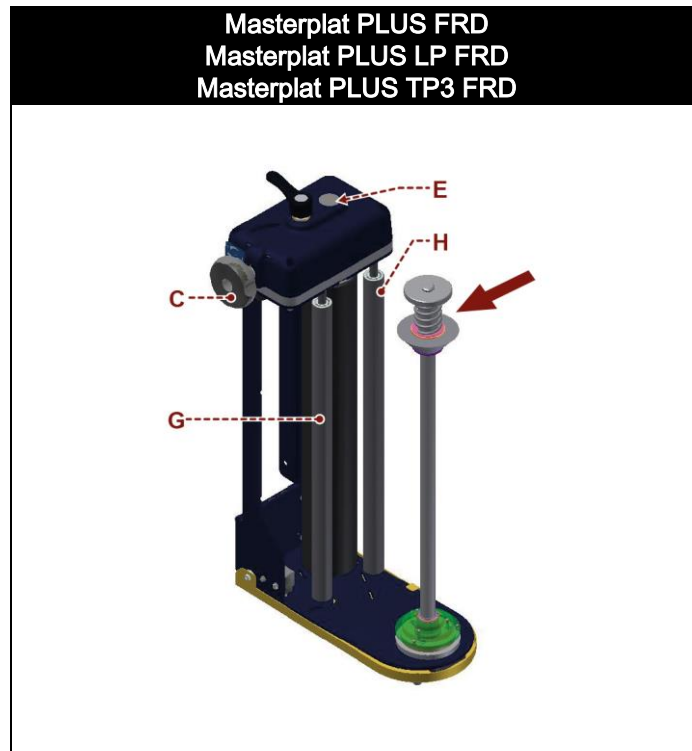

### 5.3. SPOOL CARRIAGE LIFTING CHAIN ADJUSTMENT

1. Lift the spool carriage (with the machine operating in “manual mode”) until it reaches the “upper” limit switch.
2. Switch the machine off.
3. Loosen the screws (A) and tilt the pole resting it on the plate.
4. Remove the guard (B).
5. Loosen the nuts (C).
6. Tighten the screw (D) "M8x50 UNI 5739" (not supplied) with a torque wrench (not supplied) to the torque of **3 Nm**.
7. Screw the nuts (C) again until reaching the chain tensioner (E) level.
8. Loosen the screw (D).
9. Refit the guard (B).
10. Place the pole back in its vertical position and tighten the screws (A).

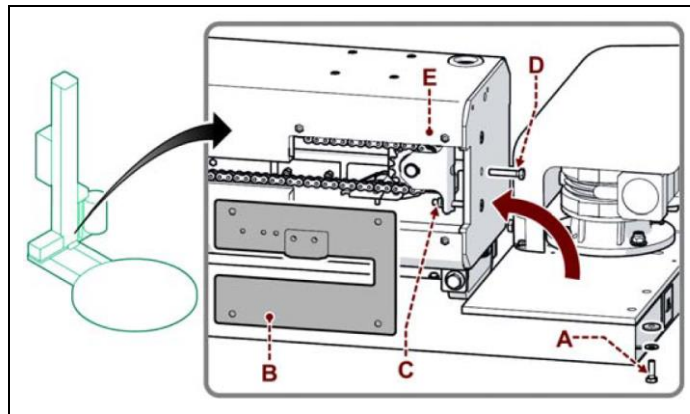

### 5.4. ROTARY TABLE CHAIN ADJUSTMENT

1. Remove the cover (A).
2. Loosen the fastening screws (B) of the reduction unit.
3. Tighten the screw (C) with a torque wrench (not supplied) to **5 Nm**.
4. Tighten the reduction unit fastening screws (B) when adjustment is completed.
5. Refit the guard (A).

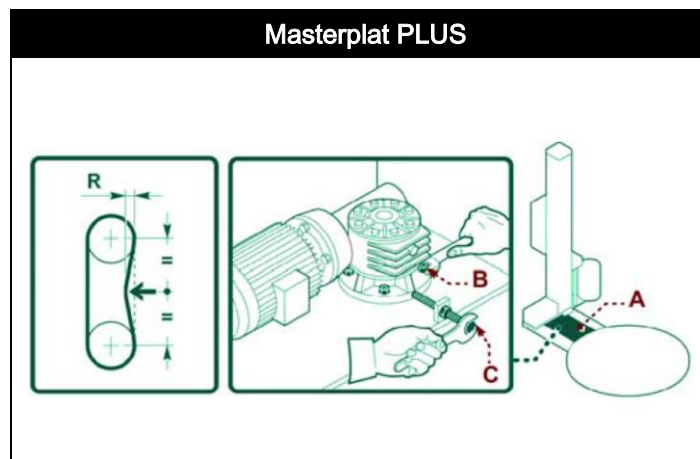



### 5.5. "TP" ROTARY TABLE CHAIN ADJUSTMENT

1. Loosen the screw (C) completely.
2. Remove the cover (A).
3. Loosen the fastening screws (B) of the reduction unit.
4. Tighten the screw (C) with a torque wrench (not supplied) to the rated torque of 3Nm.
5. Tighten the reduction unit screws (B) when adjustment is completed.
6. Loosen the screw (C) completely and refit the guard (A).

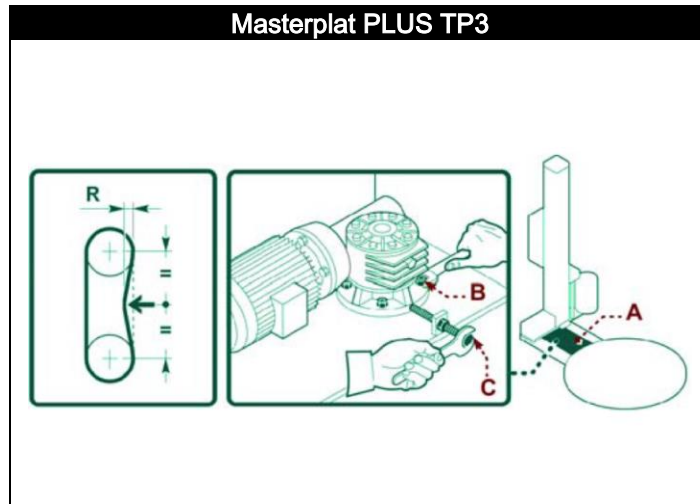

## 5.6. ADJUSTING ROTARY TABLE GEAR WHEELS

1. Remove the cover (A).
2. Loosen the fastening screws (E) and correctly position the gearmotor / gear wheel.
3. Loosen the fastening screws (D) of the gear wheels (B) and (C)
4. This adjustment must be performed at the operator's discretion by using the proper tools.



### Danger - warning

Any maintenance operation in this area must be carried out with machine stopped, with electric switch set to OFF and with no other operator near the machine.

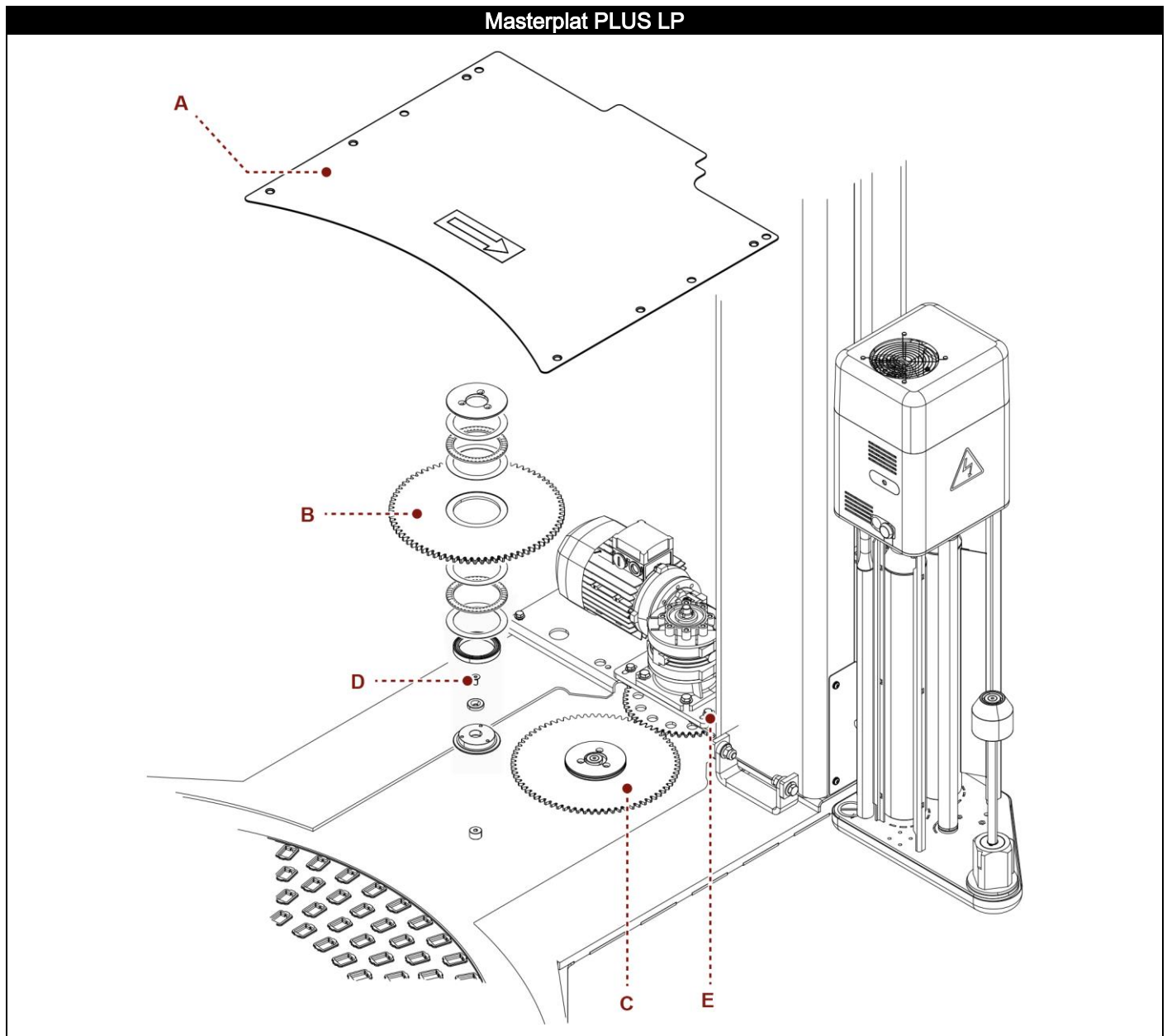

## 5.7. ADJUSTING THE TABLE GUIDE WHEELS

1. Remove the cover (A).
2. Loosen the fastening nuts (B).
3. Loosen the screw (E).
4. Tighten the screw (D) so that the wheel (C) is pressed against the rotary plate by approximately 4 mm.
5. Tighten the screw (E).
6. Tighten the nuts (B).
7. Refit the guard (A).

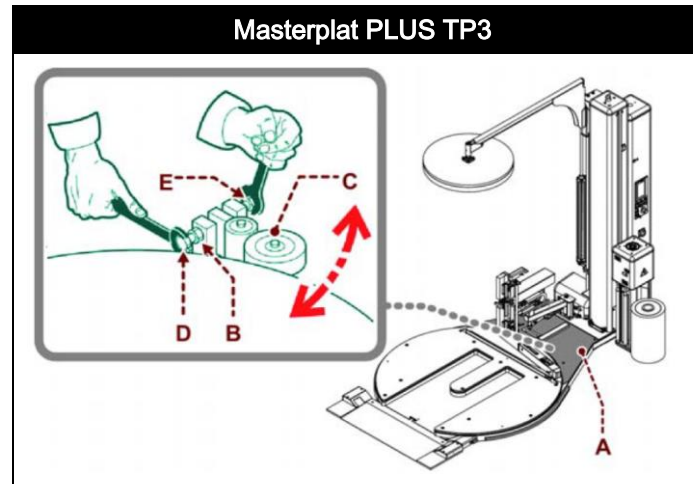

## 6. INFORMATION ABOUT THE USE

### 6.1. RECOMMENDATIONS FOR OPERATION AND USE

- When using the machine for the first time, the operator must read the manual and identify the control functions and simulate some operations, especially machine start and stop.
- Make sure that all safety devices are properly installed and efficient.
- Only carry out the operations foreseen by the Manufacturer and do not tamper with any device to obtain different performance levels.
- Daily, before each use of the machine, check that it stops by pressing the emergency button to trigger the bumper.



#### **Caution - warning**

Bumper can be triggered by placing an obstacle in front of the machine at a distance of approximately 20 cm.



#### **Important**

The frequency of the accidents derived from machine use depends on many factors that cannot always be foreseen and controlled.

Some accidents may be caused by unpredictable environmental factors, others are mainly due to users' behaviours.

On first use, and if required, in addition to being authorised and appropriately informed, the personnel must simulate some manoeuvres to identify the main controls and functions.

Only carry out the operations foreseen by the Manufacturer and do not tamper with any device to obtain different performance levels.

Make sure the safety devices are properly installed and efficient before use.

Users, besides complying with these requirements, must apply all the safety regulations and carefully read the descriptions of the controls and commissioning.

## 6.2. DESCRIPTION OF THE CONTROLS

- 1) **Emergency stop button:**  
it is used in case of imminent risk to stop, with a voluntary action, the machine parts which may pose a risk.  
For more details, see the paragraph "description of safety devices".
- 2) **User interface:**  
it is used to set or modify the machine operating parameters.  
The user interface is equipped with a display and a multi-function selector (7).  
For more details, see the paragraph "Description of user interface".
- 3) **"Cycle start" button:**  
it is used to start the wrapping automatic cycle.
- 4) **"Cycle stop" button:**  
it is used to stop the wrapping automatic cycle.
- 5) **"Reset" button:**  
it is used to reset the machine before restarting it after an emergency stop or after a shut-down due to the disconnection of the power supply.
- 6) **Emergency override key-operated switch:**  
it is used to temporarily bypass the carriage emergency.  
When the key is turned to position "I" (hold to run), the user interface screen will display the page "emergency override" and this allows, by pressing the "start" button (7), to lift only the carriage.
- 7) **Multi-function selector:**  
it allows activating and setting machine functions.  
Turn the selector (clockwise or counter-clockwise) and release it when the concerned page or function is displayed. Press to activate the selected function.
- 8) **Main disconnecting switch:** to activate and disable the power supply.  
- Pos. "O": power supply off.  
- Pos. "I": power supply on.
- 9) **Indicator light** (For "FREEZER" and "INOX" versions only).  
When the indicator is on, it indicates that the electric control panel is in heating phase.  
During this phase, any action on the controls will be ineffective.  
Once the electric panel heating phase is complete, the display will indicate that the "Reset" button (5) must be pressed.  
The heating is automatically enabled and disabled at the temperatures (minimum and maximum) set by the manufacturer.

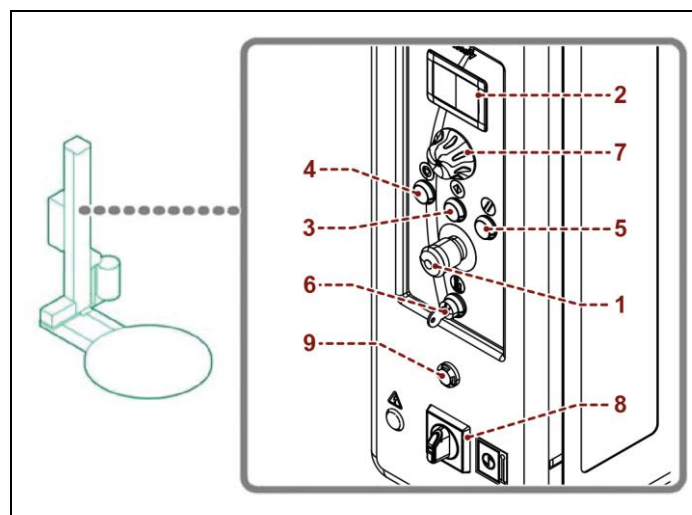

### 6.3. DESCRIPTION OF USER INTERFACE

The user interface is equipped with a multi-function selector (1), which is used to view and set the machine functions, and a display (2), which shows recipes, parameters, etc.

To view and/or set the functions, turn or press the multi-function selector.

Functional logic diagrams show the navigation modes.

The illustration corresponding to each view shows the abbreviation which indicates the activation mode.

- Abbreviation “**R**”:  
turn the control to access the views or to modify the values.  
**To modify the values, press the control, turn it until the concerned value is displayed and press it again to save it.**
- Abbreviation “**P**”:  
press the control to activate the selected function.
- Abbreviation “**PH**”:  
it indicates a long pressure of the multi-function selector (1), which allows accessing the second level functions.

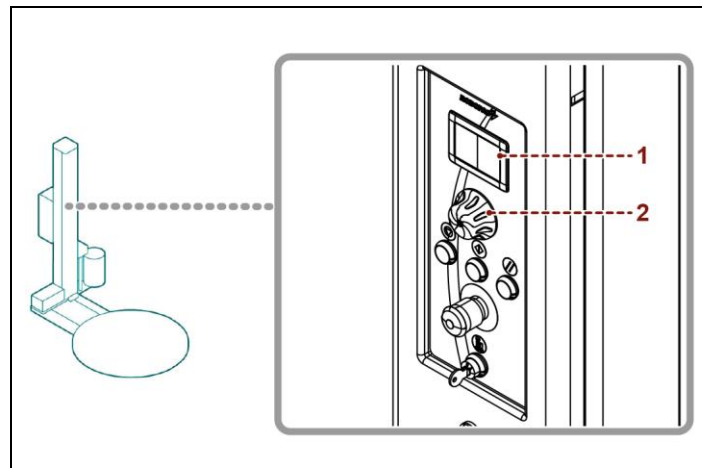

Colours of page edges:

- **Yellow**: machine in “Stop” mode with locked values (padlock function).
- **Green**: machine in “Stop” mode with editable values.
- **Purple**: machine in “Manual” mode.
- **Blue**: machine in “Reset” mode.
- **Orange**: machine in automatic “Run” mode.
- **Red**: machine in alarm mode.
- **White**: parameter value edit pages.

#### 6.4. "MAIN MENU" PAGE

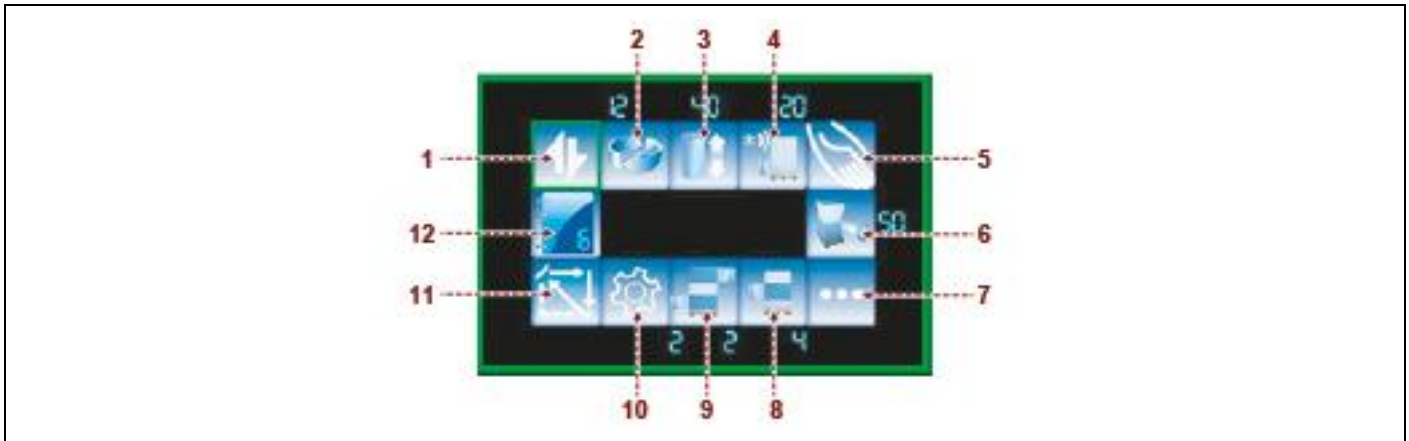

Ref.	Button	Description
1		Wrapping cycle
2		Table rotation speed (rpm)
3		Carriage speed
4		Wrapping end delay
5		Access to "Manual Controls" Menu. (See "Manual Controls Menu")
6		Access to "Film Tensioning" Menu (See "Film tensioning menu")
7		Access to "Other" Menu (See "Other Menu")
8		Intermediate wrapping turns
9		Intermediate and upper wrapping turns
10		Access to "Settings" Menu (See "Settings Menu")
11		Synchronisation of the machine: table in initial position, carriage down, presser up. If "JOG" is pressed again, movements will stop
12		Access to the "Recipe" Menu (See "Recipe" Menu)

### 6.4.1. WRAPPING CYCLE

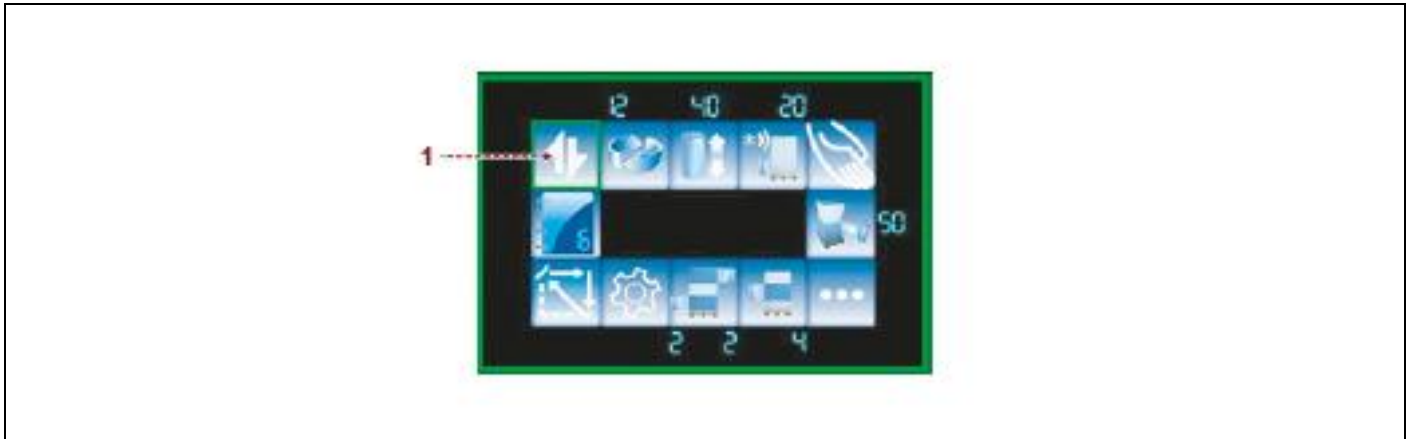

Activation mode abbreviation	Button	Description
R		“Double wrapping” cycle
R		“Single wrapping” cycle
R		“Double wrapping with feeder” cycle





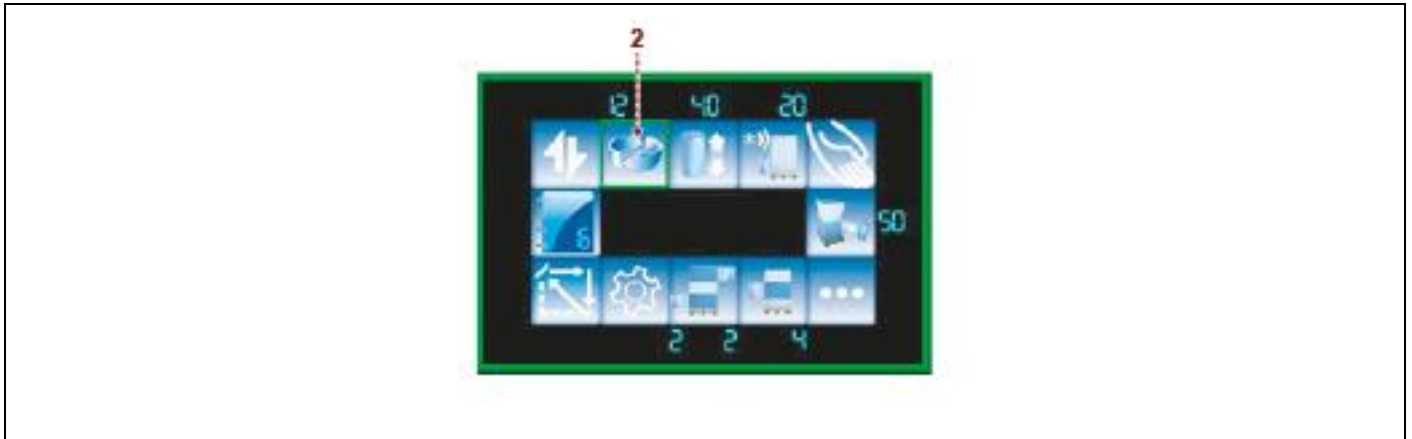

### 6.4.2. TABLE ROTATION SPEED (rpm)

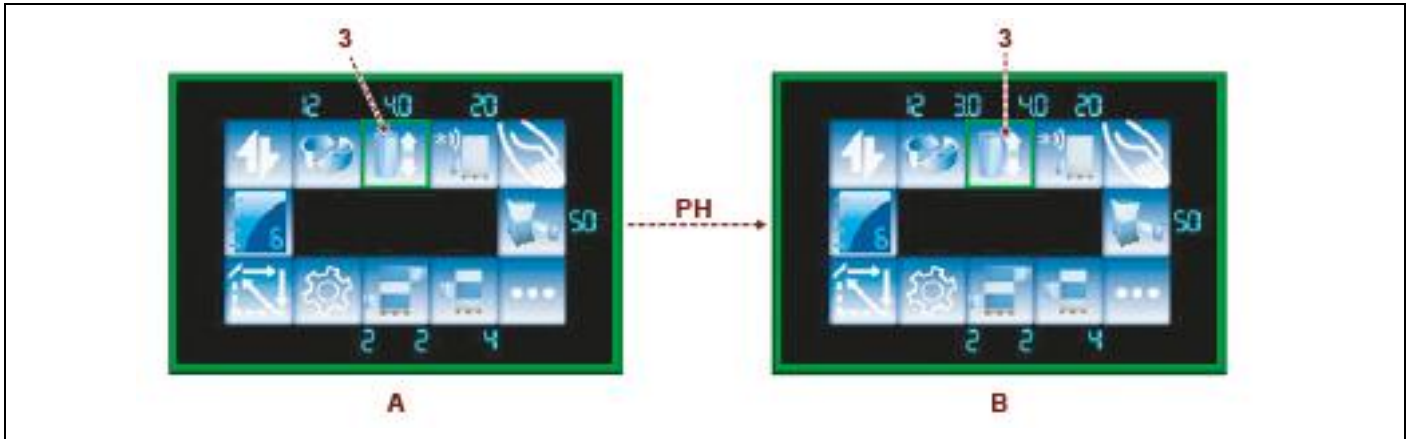

Activation mode abbreviation	Button	Description
P		Display the table rotation speed (rpm)

### 6.4.3. CARRIAGE SPEED



Ref.	Activation mode abbreviation	Button	Description
A	P		Display carriage speed
B	P		Display carriage upstroke speed
	P		Display carriage downstroke speed

#### 6.4.4. WRAPPING END DELAY / PALLET HEIGHT

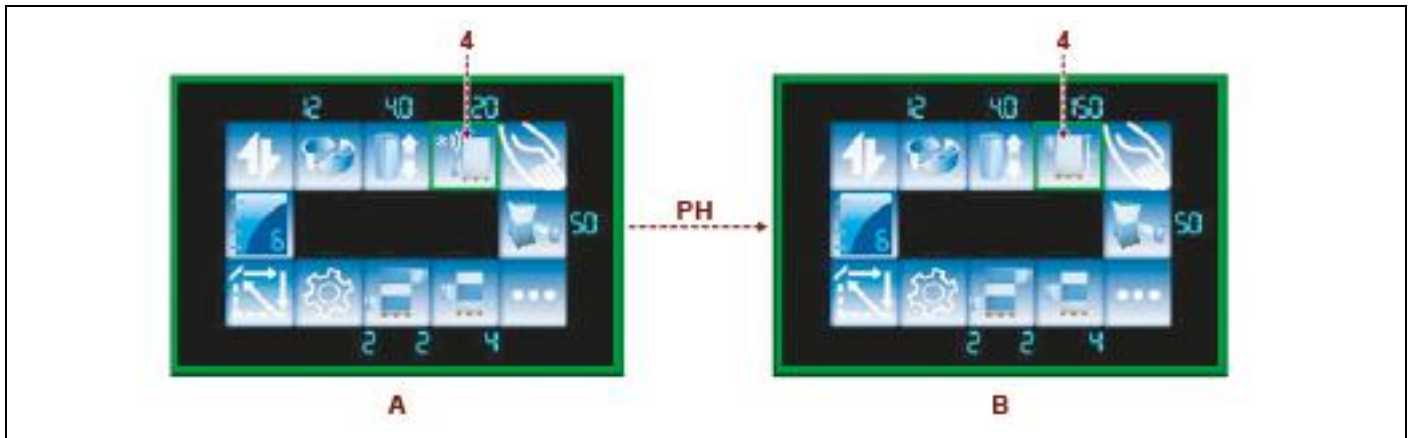

Ref.	Activation mode abbreviation	Button	Description
A	P		View the distance of the wrapping end delay in cm
	P		View the dimension of the offset from the ground in cm
B	P		View the set pallet height
	P		View the dimension of the offset from the ground in cm

### 6.4.5. MANUAL CONTROLS

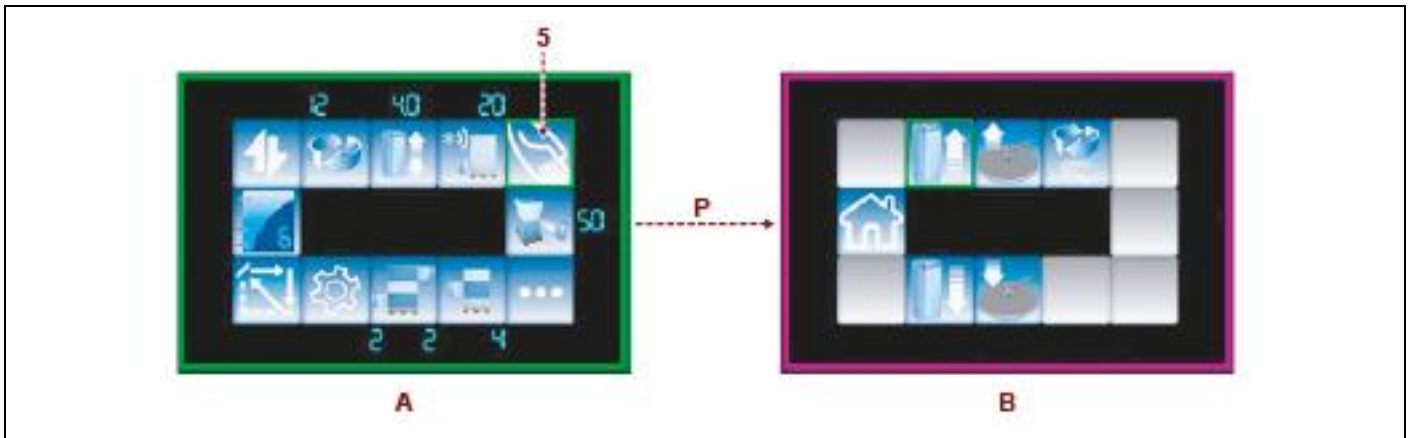

Activation mode abbreviation	Button	Description
P		Press the button (5) to access the “Manual controls” Menu.

Activation mode abbreviation	Button	Description
R		If “JOG” is pressed, the carriage (hold to run) rises until reaching the upper limit switch
R		If “JOG” is pressed, the presser (hold to run) rises until reaching the upper position
R		If “JOG” is pressed, the table (hold to run) turns until reaching the initial position
R		If “JOG” is pressed, the presser (hold to run) moves down until reaching the lower position
R		If “JOG” is pressed, the carriage (hold to run) moves down until reaching the lower limit switch
R		Return to the previous menu

### 6.4.6. FILM TENSIONING

For PGS version only

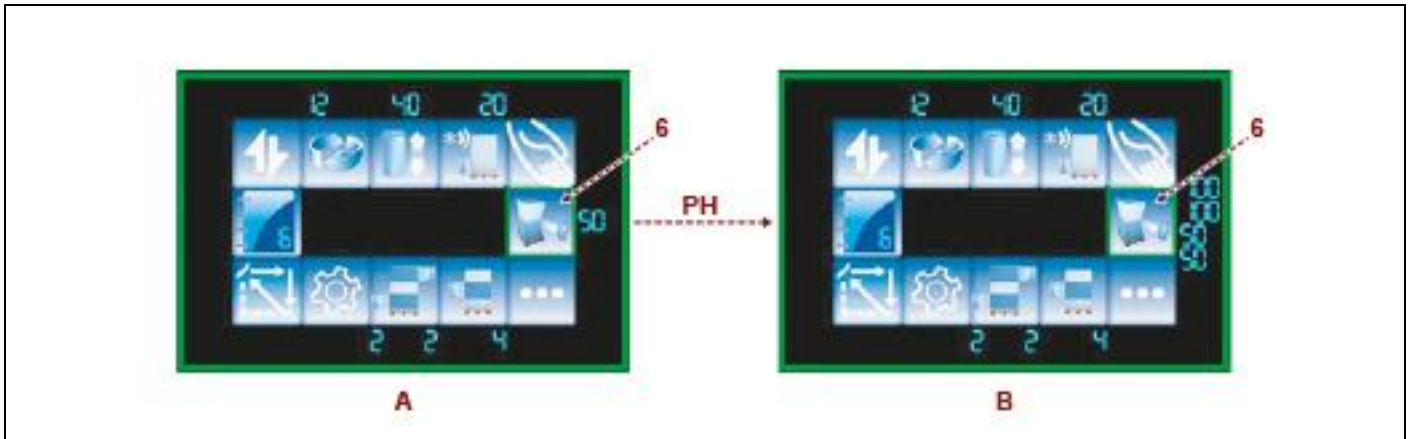

Ref.	Activation mode abbreviation	Button	Description
A	P		View the film tensioning value
B	P		View the lower film tensioning value
	P		View the film upstroke tensioning value
	P		View the upper film tensioning value
			View the film downstroke tensioning value

### 6.4.7. OTHER

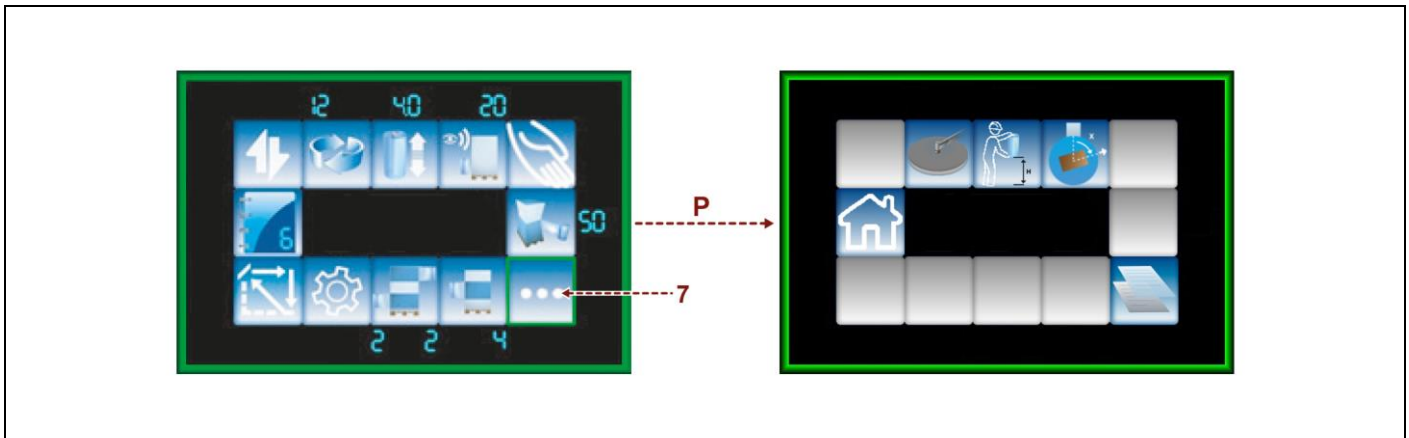

Activation mode abbreviation	Button	Description
P		Press the button (7) to access the “Other” Menu.

Activation mode abbreviation	Button	Description
R		Presser function enabling
R		“Ergonomic upstroke” function
R		“Phase angle adjustment” function
R		“Copy recipe data” function
R		Return to the Home page

Icon ref.	Code activation mode	Page	Description
	R		Presser enabled
	R		Presser disabled

	R		Selection of the carriage stop height in cm at the end of the cycle
	R		Selection of the phase angle height
	R		Selection of the recipe to copy

### 6.4.8. SETTINGS

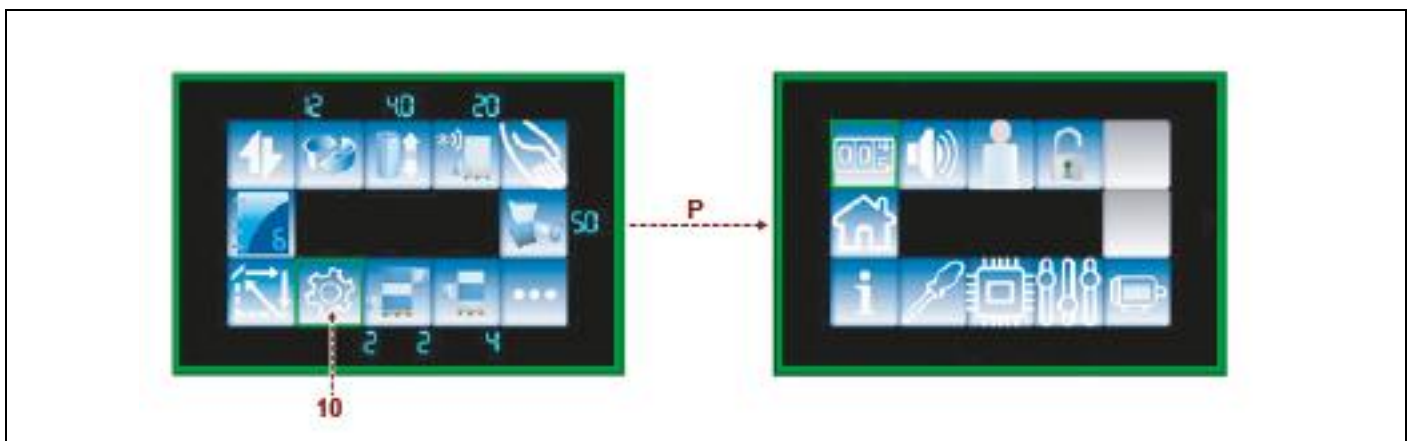

Activation mode abbreviation	Button	Description
P		Press the button (10) to access the settings Menu.





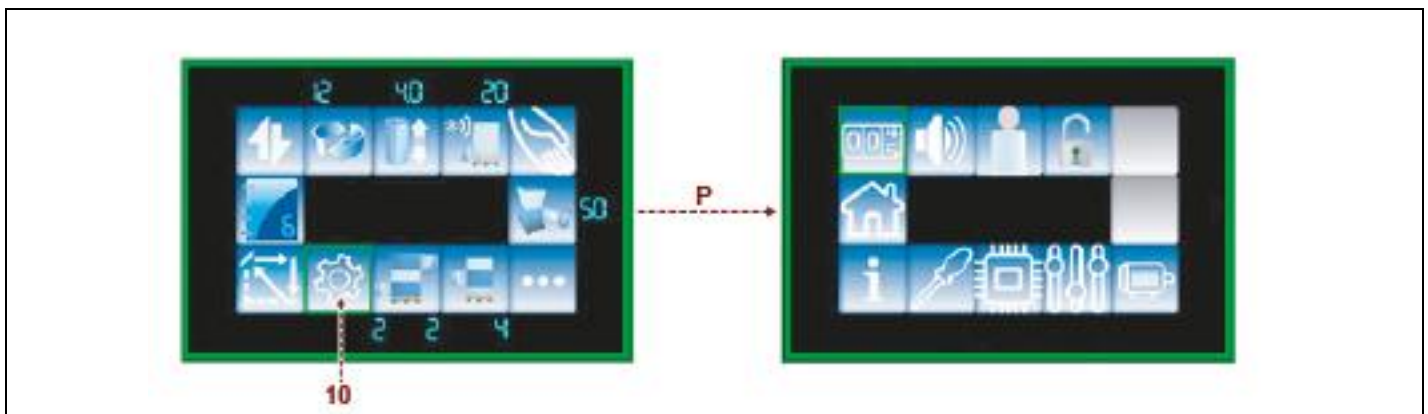

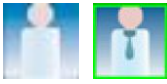

Activation mode abbreviation	Button	Description
R		Cycle counter
R		Acoustic signal
R		User. Page alternative options depend on the login status
R		Panel lock

R		Function to change the panel lock password (Available depending on to the login status and with unlocked panel)
R		Motor parameters - Assistance page
R		Machine parameters - Assistance page
R		Input/Output status - Assistance page
R		Load cell settings (PGS only)
R		Info - Assistance page
R		Return to the previous menu



Icon Ref.	Activation mode abbreviation	Page	Description
	P		View counters P = Partial T = Total H = hours
	R		Acoustic signal ON
	R		Acoustic signal OFF





	<p>P</p>		<p>Page for entering the password to change the user; Turn to select the digit and press to confirm. Select "C" to delete the password. Select the "Checkmark" to confirm the password.</p>
	<p>P</p>		<p>Enter the password (default 9999) to lock the panel. When the panel is locked, the edge of the screen is yellow.</p>
	<p>P</p>		<p>Enter the password to unlock the panel.</p>
	<p>P</p>		<p>To change the panel lock password, enter a new password and select the "checkmark". Enter the chosen password again and confirm to update its value.</p>
	<p>P</p>		<p><b>CELL</b> = Load cell reading instant value. <b>OFFSET</b> = Offset value (with film tensioning = 0). Press and keep pressed (for about 3 seconds) to set the parameter (only after logging in).</p>

### 6.4.9. RECIPE



Activation mode abbreviation	Button	Description
P		Programme

Icon ref.	Code activation mode	Page	Description
	R		Programme "1"
			Programme "2"
			Programme "3"
			Programme "4"
			Programme "5"
			Programme "6"

	<p>R</p>		<p>Manual cycle (See "Manual Cycle")</p>
			<p>"ECO" cycle (See "Eco Cycle")</p>

### 6.4.10. MANUAL CYCLE

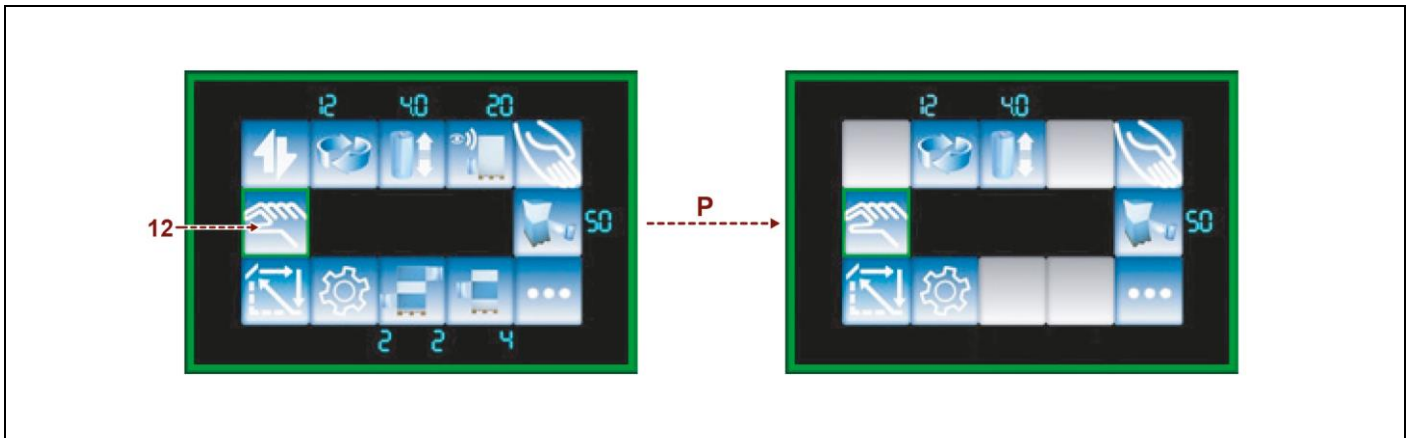

Activation mode abbreviation	Button	Description
P		Press the button (12) to access the manual cycle menu Home page Set the table rotation speed, the carriage upstroke/downstroke speed and the film stretch as previously indicated in programmes from 1 to 6.

Activation mode abbreviation	Button	Description
R		Table rotation speed
		Carriage speed
		Manual controls
		Film stretch (for PGS version only)
		Other menu
		Settings
		Synchronisation of the machine



When the “START” button is pressed, the table starts to turn and the Home page looks as follows.

Activation mode abbreviation	Button	Description
R		Table rotation speed
		Carriage upstroke/downstroke speed
		“Double wrapping with feeder” cycle
		Film stretch (for PGS version only) allow to modify the parameters just listed.
P		Carriage downstroke At every pressure, the carriage moves down or stops
P		Carriage upstroke At every pressure, the carriage moves down or stops
P		Table stop in initial position The table stops in the initial position and the cycle ends

The cycle ends when the carriage downstroke movement brings it to the lowest position or when the “STOP button is pressed.

### 6.4.11. ECO CYCLE

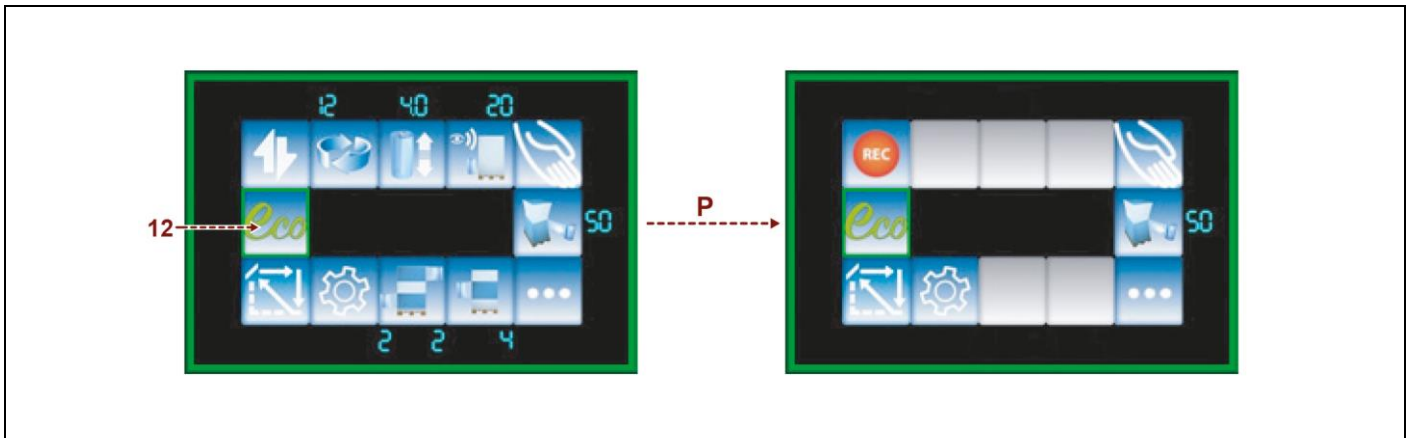





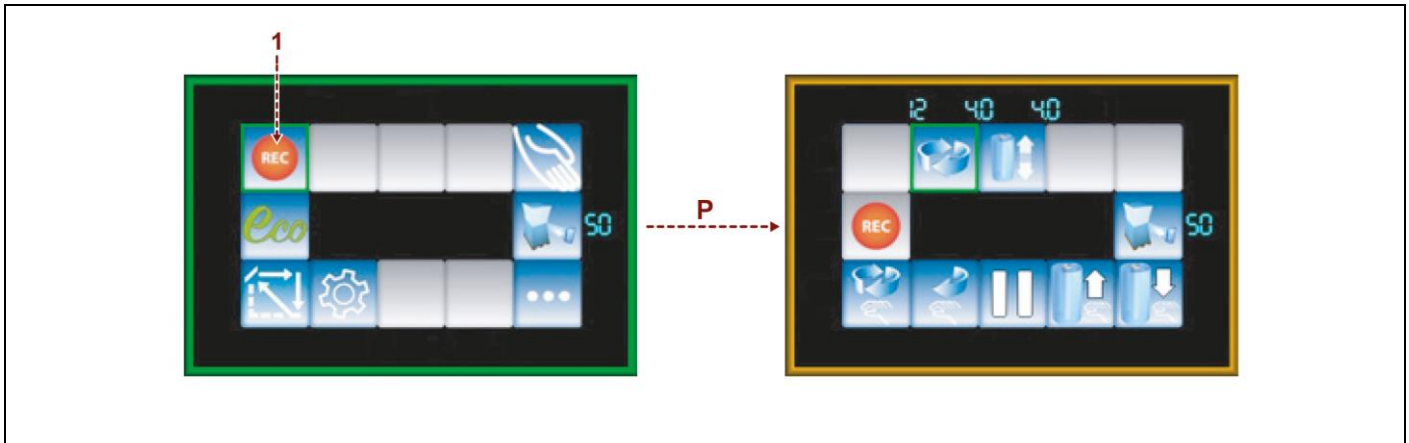

Activation mode abbreviation	Button	Description
P		Press the button (12) to access the self-learning cycle Home page.

Activation mode abbreviation	Button	Description
R		Start logging mode
		Manual controls
		Film stretch (for PGS version only)
		Other menu
		Settings
		Synchronisation of the machine



Activation mode abbreviation	Button	Description
P		Press the “Start logging mode” button (1) to access the logging mode. Set the table rotation speed, the carriage upstroke/downstroke speed and the film stretch as previously indicated in programmes from 1 to 6. Once any of these control buttons has been pressed, these values can no longer be modified.

Activation mode abbreviation	Button	Description
R		Table rotation speed
		Carriage movement speed
		Film stretch (for PGS version only)
		Carriage downstroke Start/Stop
		Carriage upstroke Start/Stop
		Cycle pause
		Table stop in initial position
		Table start.

Activation mode abbreviation	Button	Description
P		When the button is pressed, the table starts to turn.
P	    	Use the buttons to perform the required movements.
P		Press the jog button to confirm the selected control.

Press the “STOP” button to end the logging.



## 6.4.12. MISCELLANEOUS

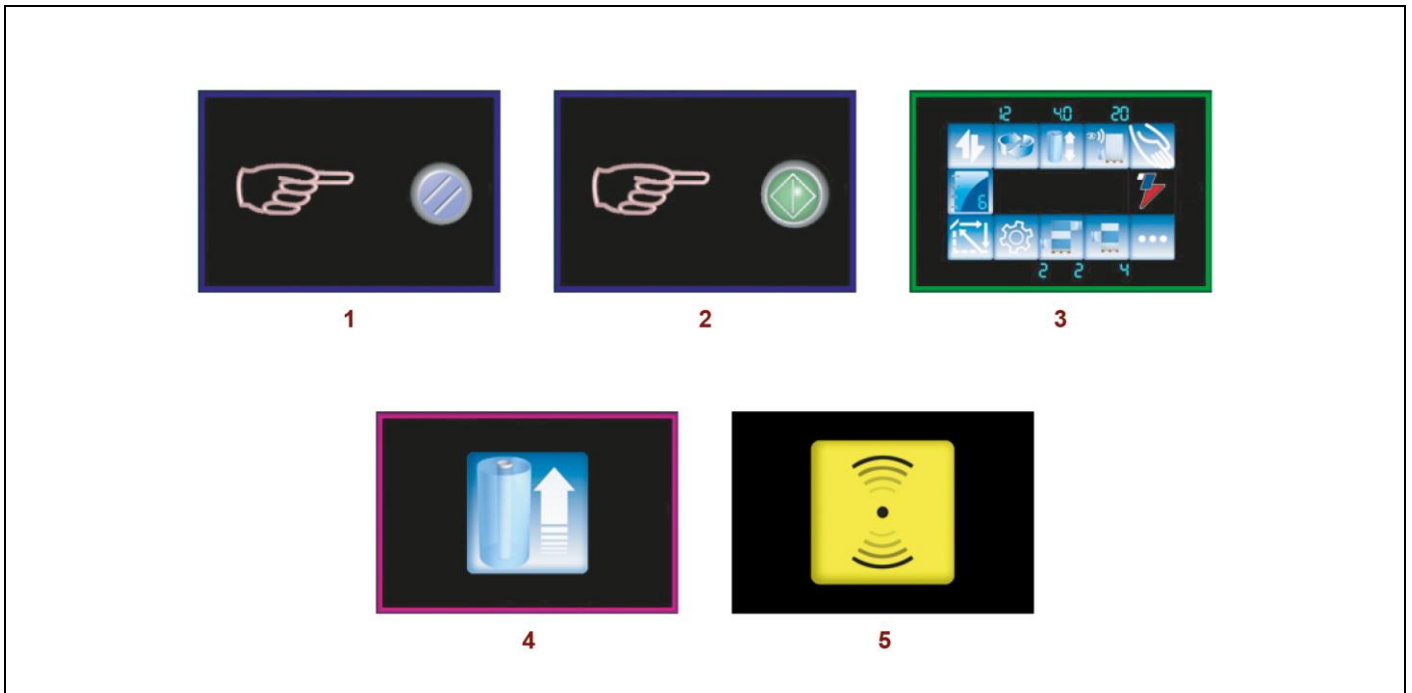

1. Press the "Reset" button.
2. Press the "Cycle Start" button.  
Restart from feeder cycle.
3. Home page if the film stretch function is absent.
4. Emergency bypassed.  
The carriage can be lifted (using the "start" button) even in case of carriage emergency.
5. Wrapping cycle in starting phase.

## 6.5. MACHINE SWITCHING ON AND OFF

1. Turn the main switch (A) to "I" (ON) to activate the power supply.  
The displayed icon indicates that the "Reset" button (B) must be pressed.

### For "FREEZER" and "INOX" versions only:

Turning the main switch (A) on automatically activates the electric control panel heating.

The panel heating phase is signalled by the lighting up of the indicator (L).

Once the heating phase, which prevents any actions on controls, is completed, the indicator (L) turns off and the display indicates that the "Reset" button (B) must be pressed.



### Caution - warning

For "FREEZER" and "INOX" versions, it is recommended not to cut off the power supply to the machine.



### Caution - warning

For "LP" versions, remove the load after the wrapping cycle.

2. Press the "Reset (B)" button.
3. Set the cycle parameters (See paragraph "cycle parameters setting").
4. Perform the cycle starting operations (see paragraph "Cycle start and stop").
5. Turn the main switch (A) to "O" (OFF) to switch the machine off.

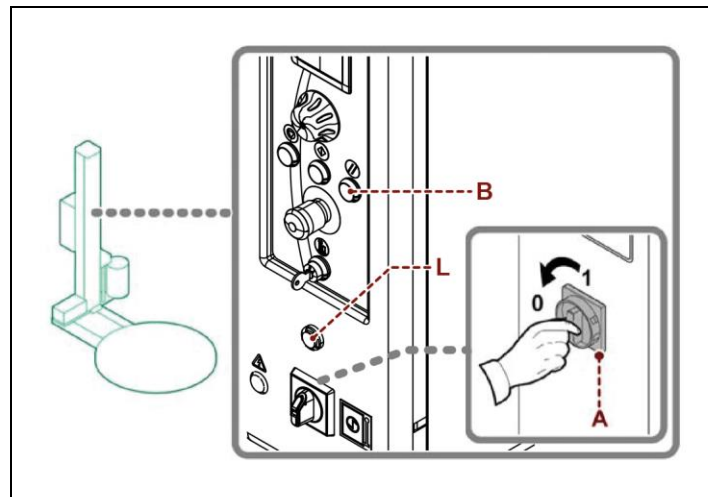

## 6.6. CYCLE PARAMETERS SETTING

6. Switch on the machine (See "Machine switching on and off").
7. Choose the recipe by turning the jog control.
8. Press the jog control to select the recipe.
9. Turn to view and modify, if necessary, the parameters already set for the recipe.
10. Press the jog control to select the parameter and turn to edit the value.  
This value will be stored in the relevant recipe.

## 6.7. DESCRIPTION OF THE WRAPPING CYCLES

### 6.7.1. SINGLE WRAPPING CYCLE

Turn the jog control to enable the wrapping cycle page.

Press the jog control and select the single wrapping.

Press the jog control to confirm.

The spool carriage starts moving from the pallet base and stops when it reaches the upper end, after having performed the required number of wrapping turns at the base and at the upper end of the pallet.

(See "Description of user interface").

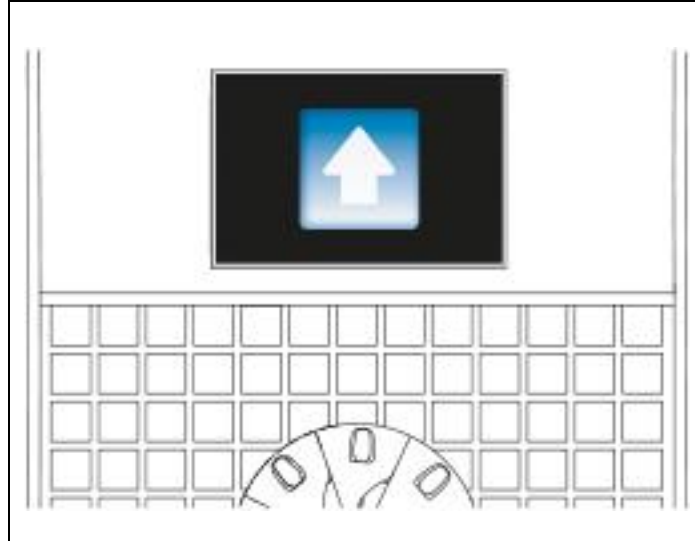

### 6.7.2. DOUBLE WRAPPING CYCLE

To select the "double cycle":

Turn the jog control to enable the wrapping cycle page.

Press the jog control and select the double wrapping.

Press the jog control to confirm.

The spool carriage starts moving from the pallet base, rises until reaching the upper end and moves down until reaching the base, performing a double load wrapping.

(See "Description of user interface").

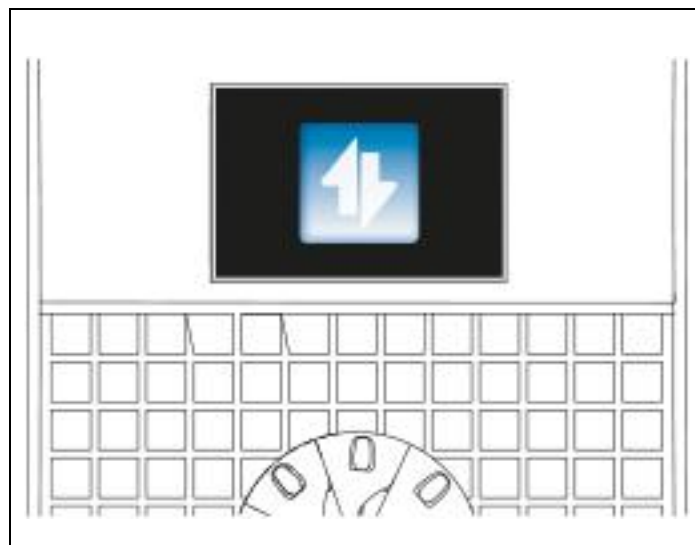

### 6.7.3. WRAPPING CYCLE WITH FEEDER

To select the cycle.

Turn the jog control to enable the wrapping cycle page.

Press the jog control and select the wrapping with feeder.

Press the jog control to confirm.

The machine performs a cycle aimed at making it easier for the operator to completely cover the pallet and ensuring the higher possible level of protection. The spool carriage rises until reaching the carriage upper end, moves down again by approximately 300 mm and stops in this position.

If the machine features a presser, it rises from the load by approximately 200 mm.

At this point, the operator, after placing the covering sheet onto the top of the pallet, activates the cycle again by pressing the "START" button: the presser moves down again.

The carriage rises until reaching the pallet upper end, performs the programmed upper wrapping turns and moves down to complete the cycle.

In this way, the position of the covering sheet, tightly bound to upward and downward film turns, is the most suitable for ensuring an optimum protection of the load against external agents (water, dust, etc.).

(See "Description of user interface").

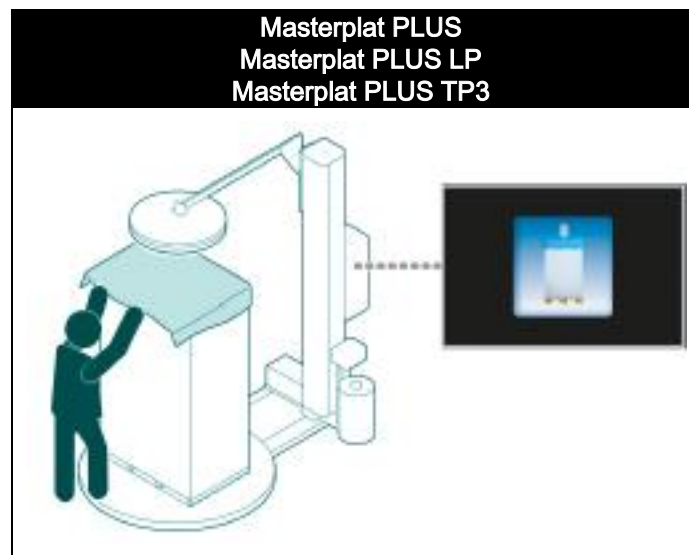

## 6.8. CYCLE START AND STOP

Proceed as follows.

1. Place the pallet on the rotary table and move the loading device away.
2. Lock the film end to the pallet.
3. Set the wrapping mode.  
For more details, see the paragraph "Description of user interface".



### Caution - warning

Do not stretch or pre-stretch the film excessively and do not wrap the product with too many wrappings in order to prevent damaging the packages and the products contained in them.

4. Press the "Cycle Start" button (A).  
The machine completes the cycle and stops automatically.
5. Cut the film.
6. Remove the pallet and position a new pallet to start a new cycle.



### Important

To temporarily suspend the cycle, press the "Cycle stop" button (B).  
Press the "Cycle Start" button (A) to restart it.

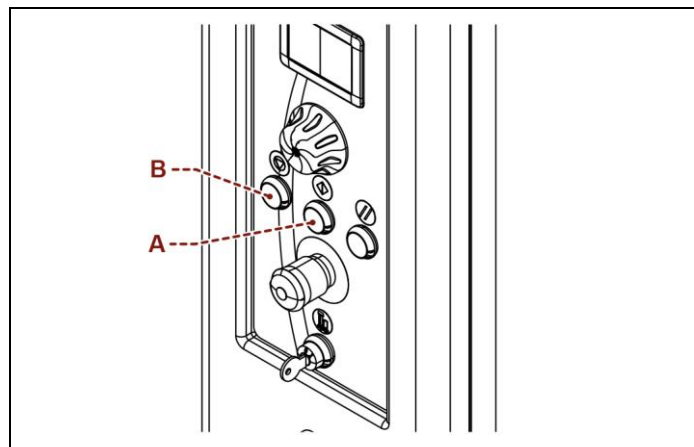

### 6.8.1. INFORMATION VALID ONLY FOR "FEEDER CYCLE" WRAPPING MODE

1. When the machine stops in the pallet upper section, position the TOP sheet (do not cut the film).
2. Press the "Cycle Start" button (A).
3. The machine performs the wrapping and, at the end of the set cycle, it stops at the pallet base.

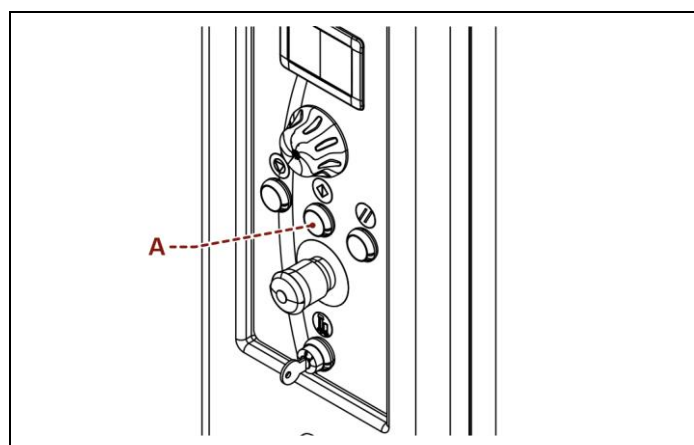

### 6.9. PRESSER HEIGHT CHANGE

- Presser unit can be supplied with pneumatic (stroke 800) or mechanical cylinder version.
- The illustrations show the machine with the presser unit in the available versions.
- See tables to find the minimum height of the pallet to be wrapped in accordance with the version of the presser installed on the machine.



**Caution - warning**

For "LP" versions, remove the load after the wrapping cycle

### 6.10. PNEUMATIC CYLINDER WITH ROD

1. Loosen the screw (A).
2. Adjust the height of the pneumatic cylinder (B) on the guide (C) according to the size of the product to be wrapped.
3. Tighten the screw (A).

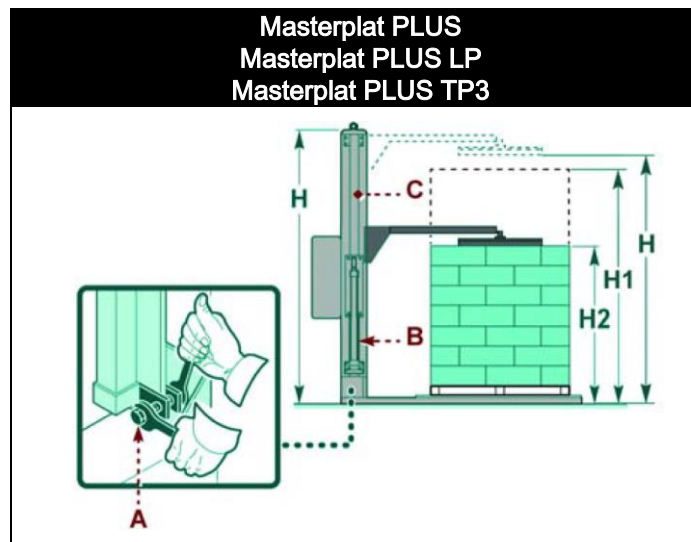

Presser unit version	Slide shaft H (mm)	Arm in normal position H1 (mm)	Arm in normal position H2 (mm)
Pneumatic cylinder with rod	2350	2200	1400
	2550	2400	1400
	2950	2800	1400
	3250	3100	1400

## 6.11.SPOOL LOADING

1. Insert the film spool into its seat on the spool carriage.
2. Gather the film to make a thin cord and make it pass between the double-cone surfaces.



### Important

Unwind the film following the path engraved on the spool carriage plate.

3. Pull the cord outwards.  
The film automatically moves down to the roller and covers it over its entire length.
4. Lock the film end into the suitable locking disc (A) on the rotary table.

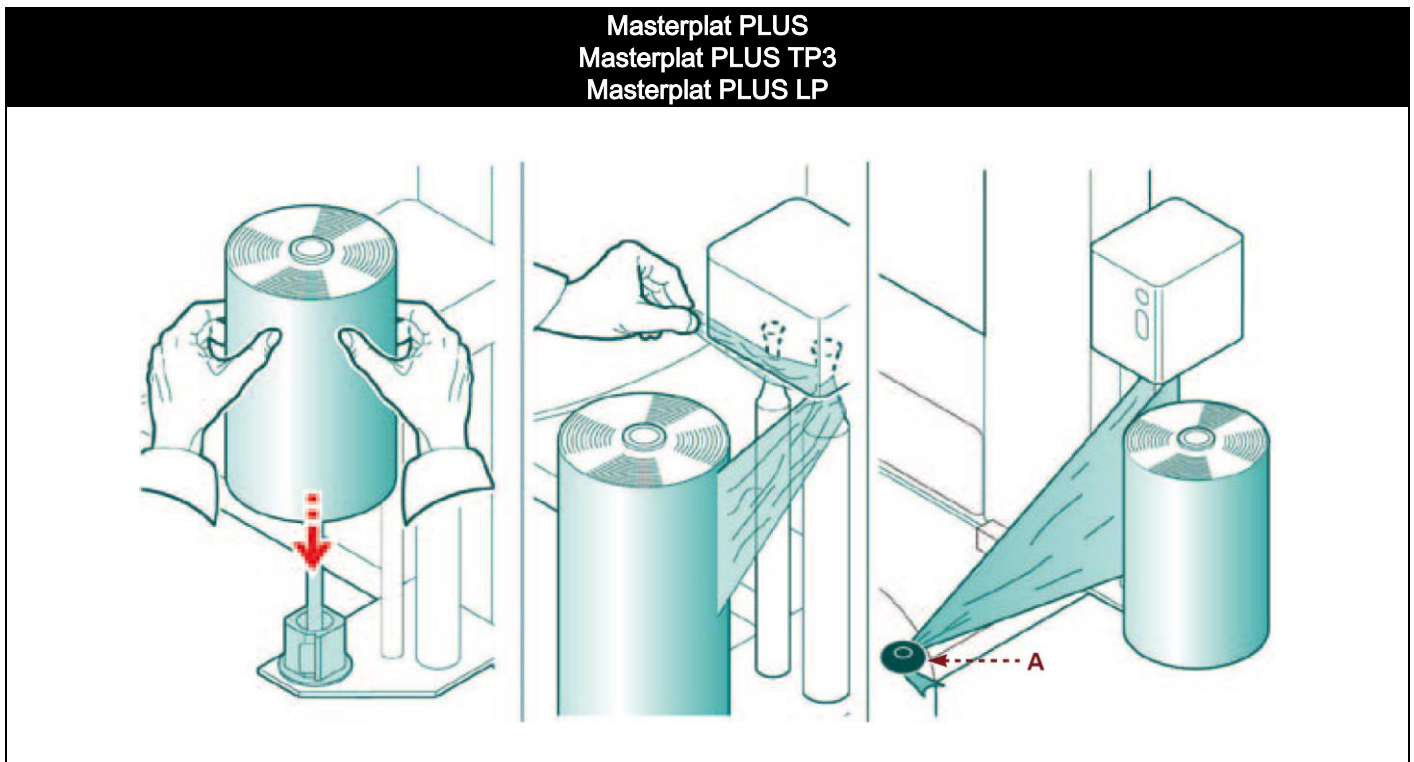

To allow film or mesh routing between rollers and unwinding on carriages of “FRD” type, it is necessary to unlock the brake by turning the handwheel (B) to pos. “0”.

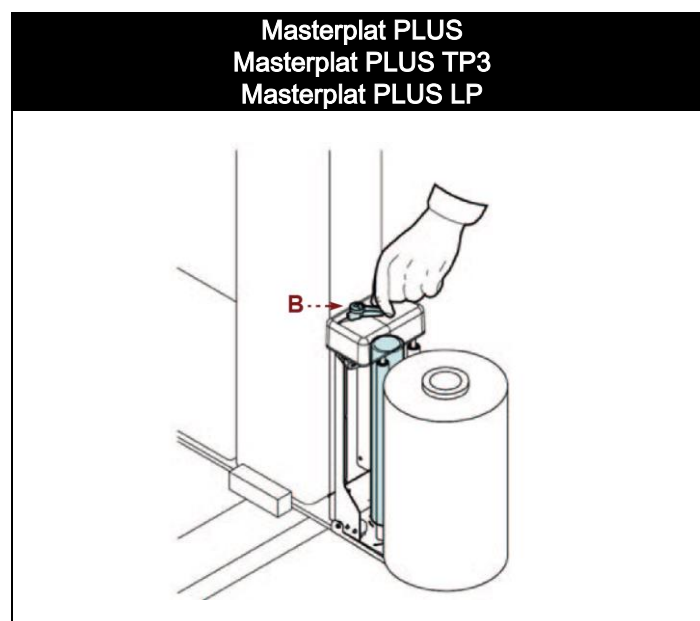

To allow film unwinding on carriages of "PGS" type, it is necessary to press the roller rotation button (C) on the spool carriage.

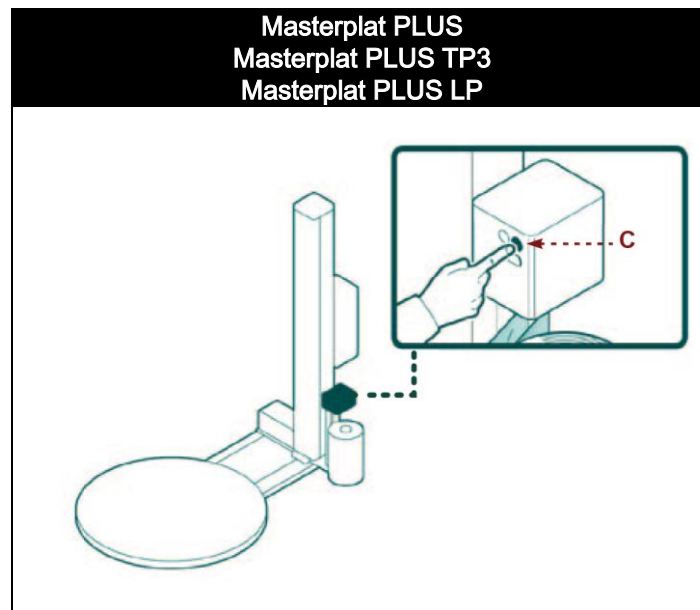



## 7. MAINTENANCE INFORMATION

### 7.1. RECOMMENDATIONS FOR MAINTENANCE

- Proper maintenance will allow a longer life span and constant compliance with safety requirements.
- Before performing any operation, the authorised operator must make sure to have understood the "Instructions for use".
- Pay attention to the safety warnings, do not misuse the machine and assess the possible residual risks.
- Carry out the interventions with all the safety devices enabled and wear the required PPE.
- Indicate the intervention areas and prevent access to the devices that, if activated, could cause unexpected hazards and compromise safety.
- Do not carry out interventions that are not described in the manual but contact an service centre authorised by the Manufacturer.
- Do not dispose of materials, polluting liquids and the waste generated during the interventions into the environment but dispose of them according to the standards in force.



#### **Danger - warning**

Before performing any maintenance operation, activate all safety devices provided and evaluate whether it is necessary to inform the personnel operating on the machine and the personnel nearby.

In particular, demarcate the neighbouring areas to prevent access to the devices that could, if activated, cause unexpected hazardous conditions posing a risk for people's safety and health.



#### **Danger - warning**

Maintenance operations must be performed with the machine disconnected from the power and pneumatic supplies.

The periodical check of the operation of some of the most important parts of the machine, may help to avoid operation problems and to maintain the machine to the maximum operating levels.

## 7.2. PERIODICAL MAINTENANCE INTERVALS



### Important

Keep the machine in maximum efficiency conditions and perform all the scheduled maintenance operations provided for by the Manufacturer.

Proper maintenance will provide the best performance, a longer life span and constant compliance with safety requirements.

### Maintenance interval table

Frequency	Component	Type of intervention	Intervention mode	Reference
Every 40 hours or 1000 cycles (*)	Machine	Cleaning	cloth or air blow	-
	Air filter unit	Condensate drainage	-	See "Condensate drainage"
		Filter cleaning	Clean with an air jet and alcohol	See "Cleaning the air filter"
Every 200 hours or 5000 cycles (*)	Rubber rollers	Cleaning	Clean with alcohol	-
	Lifting chains	Greasing	-	See "Lubrication point diagram"
		Tensioning check	Adjust	See "Spool carriage lifting chain adjustment"
	Table rotation chain	Greasing	-	See "Lubrication point diagram"
		Tensioning check	Adjust	See "Rotary table chain adjustment"
	Reduction units and gearmotors	Checking lubricant level <sup>1</sup>	Top up, if necessary, with lubricant of the same type	See lubricant table
	Gear wheels of carriage pre-stretch gears	Greasing	-	See "Lubrication point diagram"
Every 2000 hours or 10000 cycles (*)	Lifting chains	Wear check	-	-
	Safety devices	Efficiency check	-	-
	Table rotation chain	Wear check	-	-
Every 5000 hours or 50000 cycles (*)	Rotary table wheels	Replacement	-	See "Replacing the rotary table wheels"
	Carriage lifting wheels	Replacement	-	-
	Reduction units and gearmotors	Lubricant change <sup>1</sup>	Use lubricant with the same characteristics	See lubricant table

### Extraordinary maintenance

Frequency	Component	Type of intervention	Intervention mode	Reference
Every 5 years (Masterplat PLUS TP3)	"Reset" button	Replacement	Replace	-

- 1 Reduction units and gearmotors can be lubricated with grease, oil or for life, depending on their type. Topping up and/or change must not be performed in case of life-lubed reduction units and gearmotors.
- \* Cycle timings have been defined on the basis of the standard cycle.  
The standard cycle is the following: **500 mm** high film spool, **1500 mm** high pallet, pallet weight equal to **1500 kg**, total wrapping cycle consisting of two turns at the base, two turns at the top with rotation speed of **12 r.p.m.** or **80 m/1'** and carriage upstroke and downstroke speed equal to **4 m/1'**.

### 7.3. LUBRICATION POINT DIAGRAM

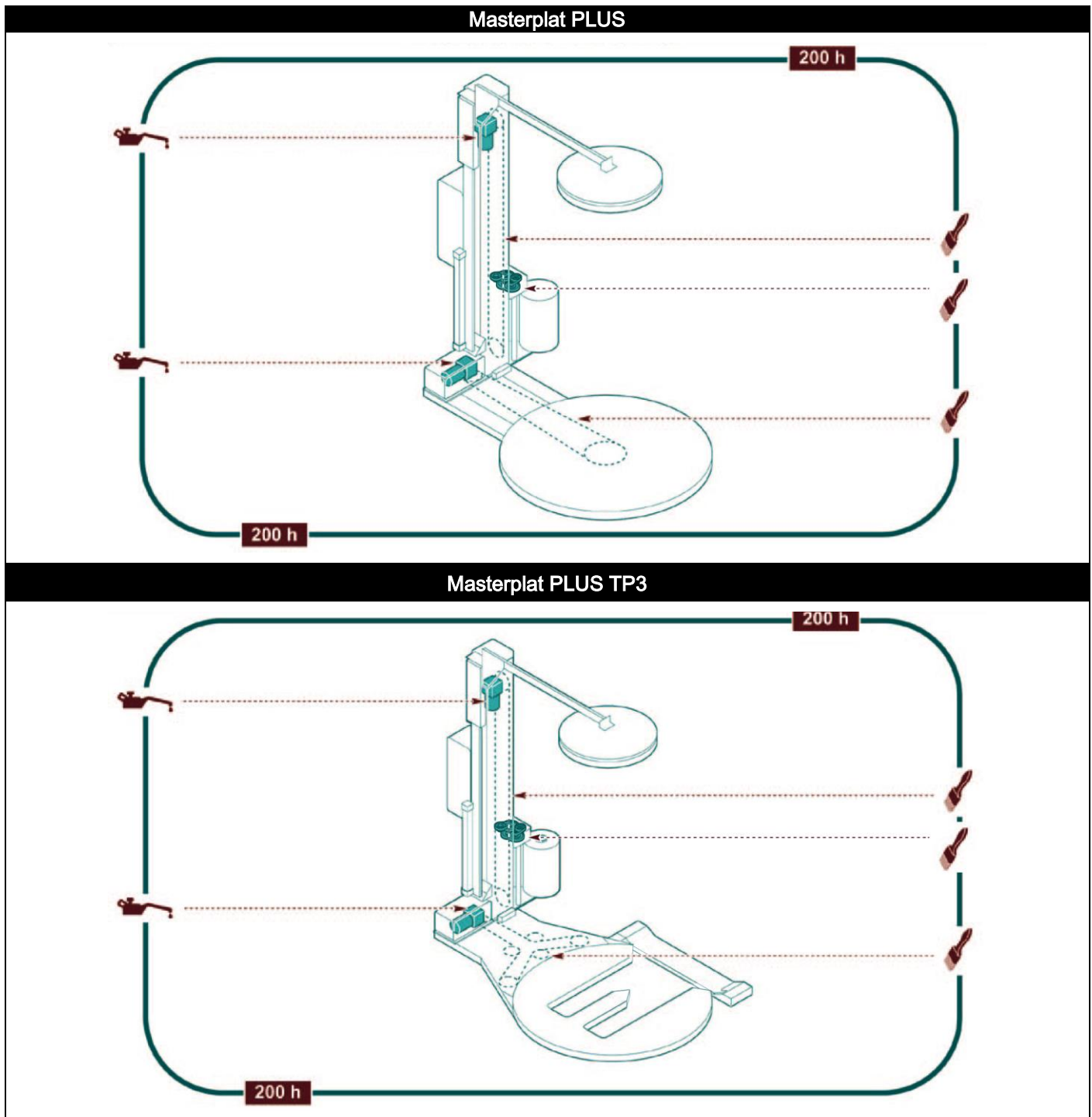

The diagram shows the main parts concerned by the lubrication interventions and their intervals.

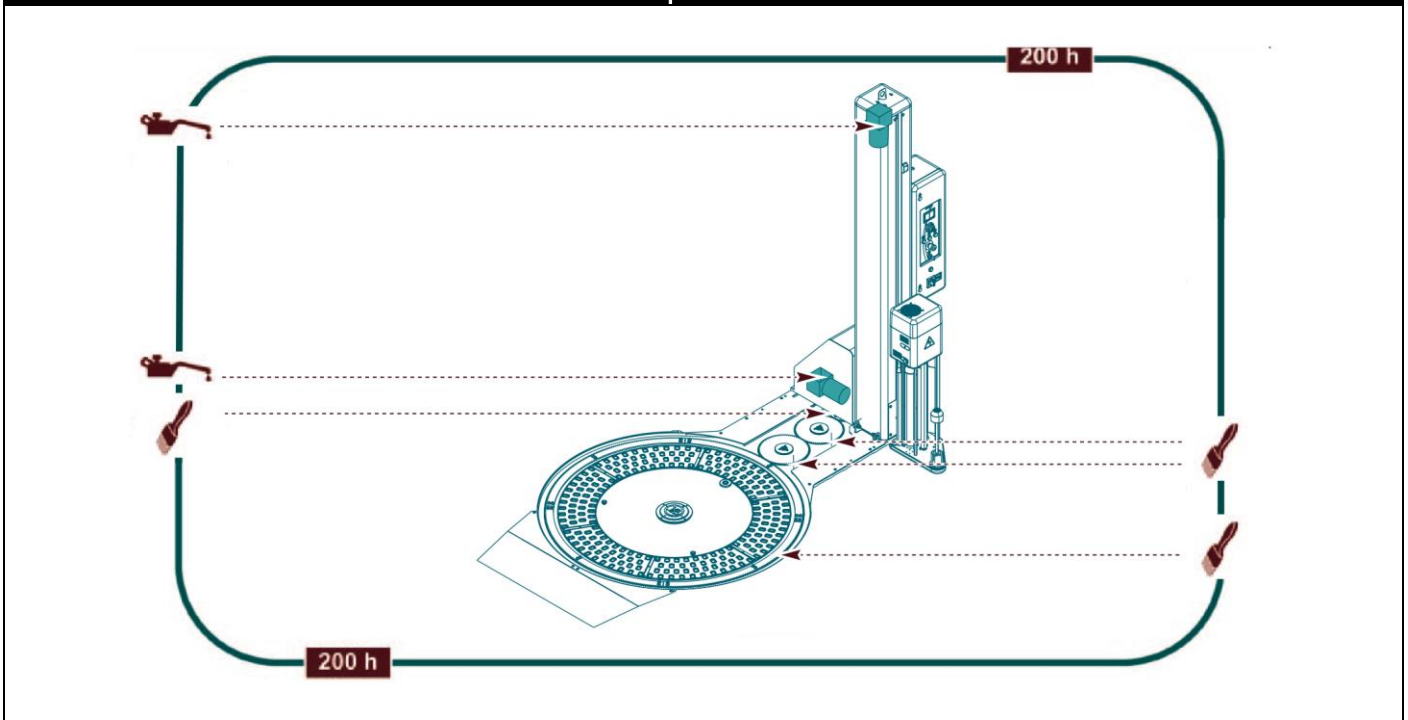

	Spread grease over it.
	Check the lubricant level. Do not top up and/or change in life-lubed reduction units and gearmotors.

**Masterplat PLUS LP**



	<p>Spread grease over it.</p>
	<p>Check the lubricant level. Do not top up and/or change in life-lubed reduction units and gearmotors.</p>

## 7.4. LUBRICANT TABLE

The table includes the specifications of the lubricants recommended by the Manufacturer on the basis of reference components and/or areas.

**Use lubricants (oils or grease) recommended by the Manufacturer or with similar chemical-physical features.**

### Lubricant characteristics

#### Masterplat PLUS - Masterplat PLUS TP3 - Masterplat PLUS LP

Lubricant type	Code	Parts to be lubricated
Mineral oil	23°C / 50°C - 320 CST 40°C MELLANA OIL 320 IP SPARTAN EP 320 ESSO BLASIA 320 AGIP MOBILGEAR 632 MOBIL OMALA EP 320 SHELL ENERGOL GR-XP 320 BP	Gear reduction unit
Mineral oil	32°C / 50°C - 460 CST 40°C MELLANA OIL 460 IP SPARTAN EP 460 ESSO BLASIA 460 AGIP MOBILGEAR 634 MOBIL OMALA EP 460 SHELL ENERGOL GR-XP 460 BP	Worm screw reduction unit
Grease	TELESIA COMPOUND B IP STRUCTOVIS P LIQUID KLUBER TOTALCARTER SYOO TOTAL	Gear reduction unit and worm screw reduction unit
Synthetic oil	TELESIA OIL IP SYNTHESO D 220 EP KLUBER BLASIA S 220 AGIP	Gear reduction unit and worm screw reduction unit
Lithium grease	ALVANIA R2 SHELL HL 2 ARAL ENERGREASE LS2 BP BEACON 2 ESSO MOBILIX MOBIL	Bearings with support
Synthetic oil	-5°C / +5°C VG 68 (SAE 20) +5°C / +25°C VG 100 (SAE 30)	Spool carriage lifting chain
Synthetic oil	+25°C / +45°C VG 150 (SAE 40) +45°C / +70°C VG 220 (SAE 50)	Table rotation chain



#### Important

Do not mix together oils of different brands or having different characteristics.

### Lubricant characteristics

#### Masterplat FREEZER – Masterplat INOX

Lubricant type	Code	Parts to be lubricated
Grease	KG1 POLILUB WH 2 MULTIFUNCTIONAL KLUBER	Bearings with support
Oil	KLUBEROIL-4-UH1-68 KLUBER	Spool carriage lifting chain
Oil	KLUBEROIL-4-UH1-68 KLUBER	Table rotation chain



#### Important

Do not mix together oils of different brands or having different characteristics.

## 7.5. CONDENSATE DRAINAGE

1. Close the tap (A) and check the level of condensation in the container (B).
2. Unscrew, if necessary, the valve (C) to drain the condensation.
3. Push the valve (C) upwards until all condensation is let out.
4. Tighten the valve (C) again.

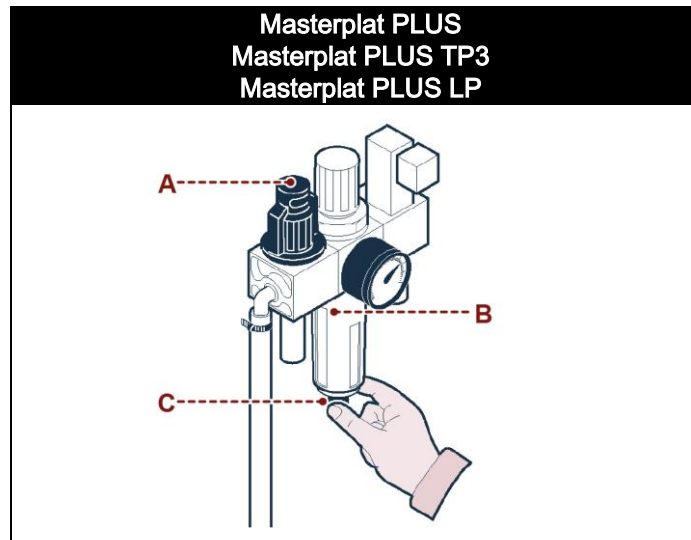

## 7.6. AIR FILTER CLEANING

1. Unscrew the container (B) with the specific wrench.
2. Remove the filter, clean it with compressed air and wash it, if necessary, with petrol or trichloroethylene.
3. Refit the filter and tighten the container (B).

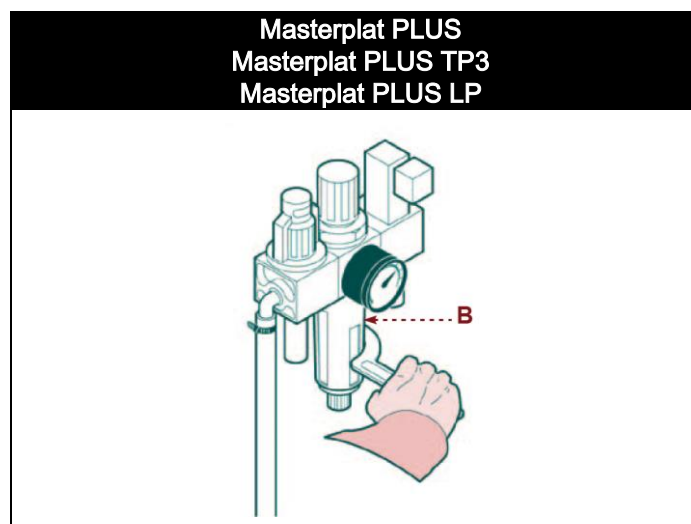

## 7.7. MACHINE CLEANING

General cleaning of the machine is fundamental to guarantee its efficiency over time.

The whole machine must be kept free from dust, dirt and foreign bodies.

The chrome-plated shafts must be cleaned with a cloth and slightly lubricated with a cloth soaked in Vaseline oil.

The parts in plastic material (1) must be cleaned with a slightly damp cloth; do not use alcohol, petrol or solvents.

Use only a dry cloth to dust the control panel (2).

For the cleaning of the parts inside the machine consult our technical assistance service.

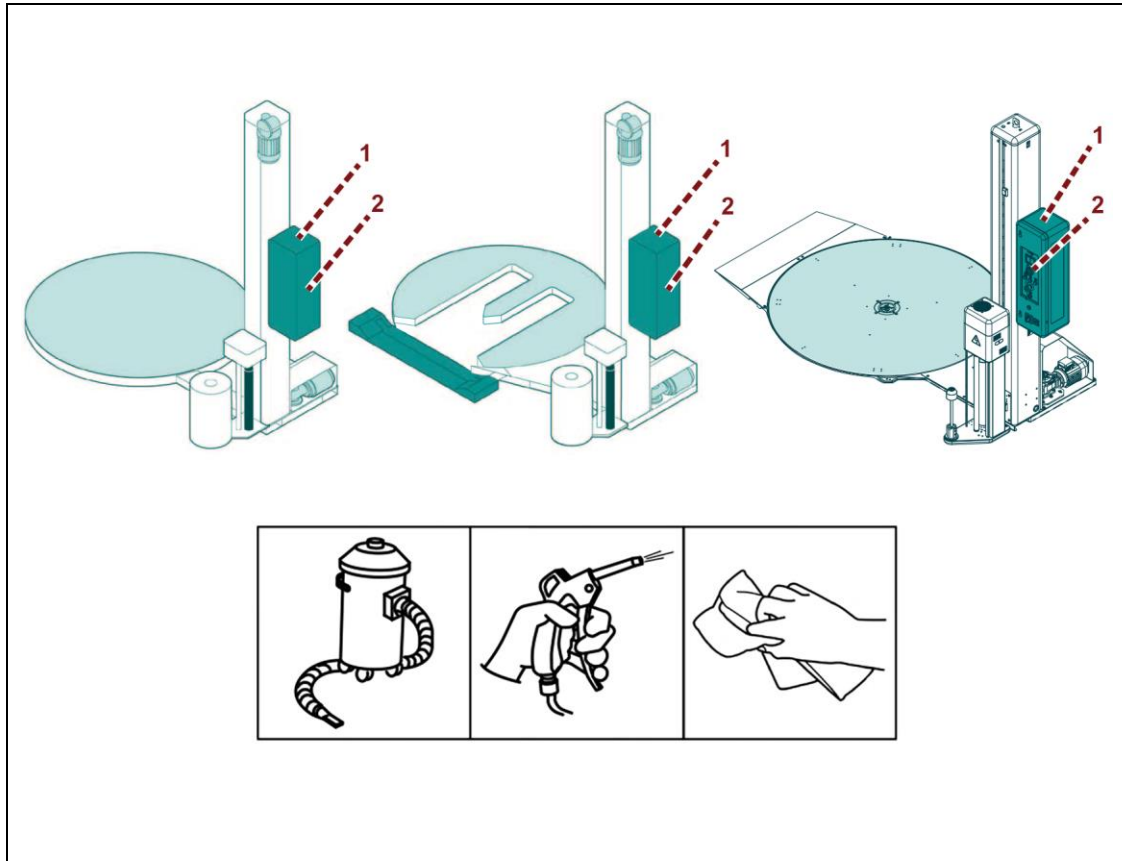



## 8. FAULT INFORMATION

### 8.1. ALARM MESSAGES

In the event of a breakdown during operation the machine stops automatically and alarm messages appear on the display.

The table lists the displayed messages, the type of problem, the causes and possible solutions.



#### Important

For these operations a precise technical expertise or ability is required; therefore, these operations must be exclusively performed by qualified personnel with certified experience acquired in the specific field of intervention.

#### List of alarms

Code	Problem	Cause	Solution
E01	Emergency mushroom-head button alarm.	Emergency mushroom-head button pressed	Reset the button and press the "Reset" button
E02	Carriage emergency	An obstacle has been detected along the trajectory during the spool carriage downstroke.	Remove the obstacle and press the "Reset" button
E03	Hand pallet truck emergency	An obstacle has been detected on the pallet loading/unloading ramp.	Remove the obstacle and press the "Reset" button
E04	Protection alarm	Intervention of safety barriers or open door	Remove the obstacle and press the "Reset" button
E30	Inverter alarm: 1. Table 2. Carriage 3. Stretch	Motor faults	Contact technical support
E60	"Film breakage" alarm	The film has broken or spool is finished	Insert the film or replace spool.
E61	Blocked table alarm	A fault or an obstacle is preventing the table from moving	Solve the fault or remove the obstacle and press the "Reset" button
E83	Error alarm Communication	Electronic fault	Contact technical support

## 9. REPLACEMENT INFORMATION

### 9.1. RECOMMENDATIONS FOR REPLACING MACHINE PARTS

- Before performing any operation, the authorised operator must make sure to have understood the "Instructions for use".
- Carry out the interventions with all the safety devices enabled and wear the required PPE.
- Demarcate the surrounding areas and put in place adequate safety measures, as provided for by the standards on workplace safety, in order to prevent and minimise the risks.
- Do not carry out interventions that are not described in the manual but contact an service centre authorised by the Manufacturer.
- Do not dispose of materials, polluting liquids and the waste generated during the interventions into the environment but dispose of them according to the standards in force.
- Replace the components only with original spare parts or parts with similar design and construction features. The use of similar but non-original spare parts may result in improper repairs, altered performance and economic damage.
- Safety components and/or devices must be replaced only with original spare parts to preserve the safety level required.



#### **Important**

Before performing any maintenance operation, activate all safety devices provided and evaluate whether it is necessary to inform the personnel operating on the machine and the personnel nearby. In particular, demarcate the neighbouring areas to prevent access to the devices that could, if activated, cause unexpected hazardous conditions posing a risk for people's safety and health. When replacing worn parts, use only original spare parts. The Manufacturer is not responsible for any damage to property or injuries to people caused by the use of non-genuine spare parts or which may result from repairs not authorised by the Manufacturer. When ordering new spare parts, follow the instructions given in the spare parts catalogue.

## 9.2. REPLACING THE ROTARY TABLE WHEELS

1. Loosen the screws (A).
2. Fit the eyebolts (B) and remove the upper plate (C).
3. Lift the table and place it on the ground.
4. Replace the wheels (D).
5. Reposition the table on the base and fasten it with the screws.

Masterplat PLUS LP

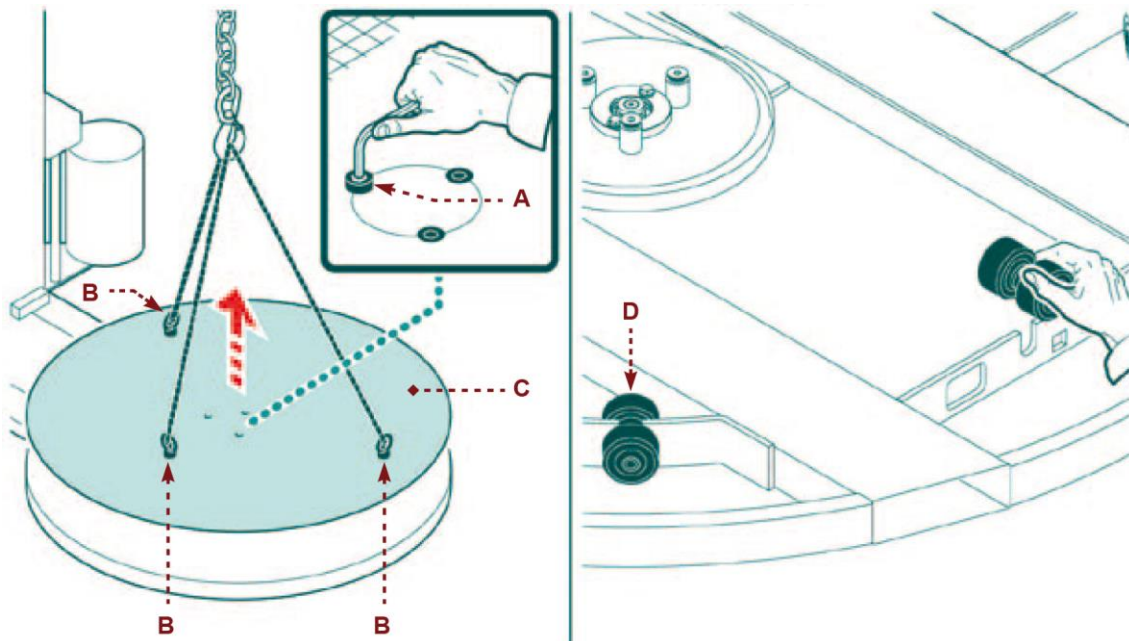

Masterplat PLUS TP3

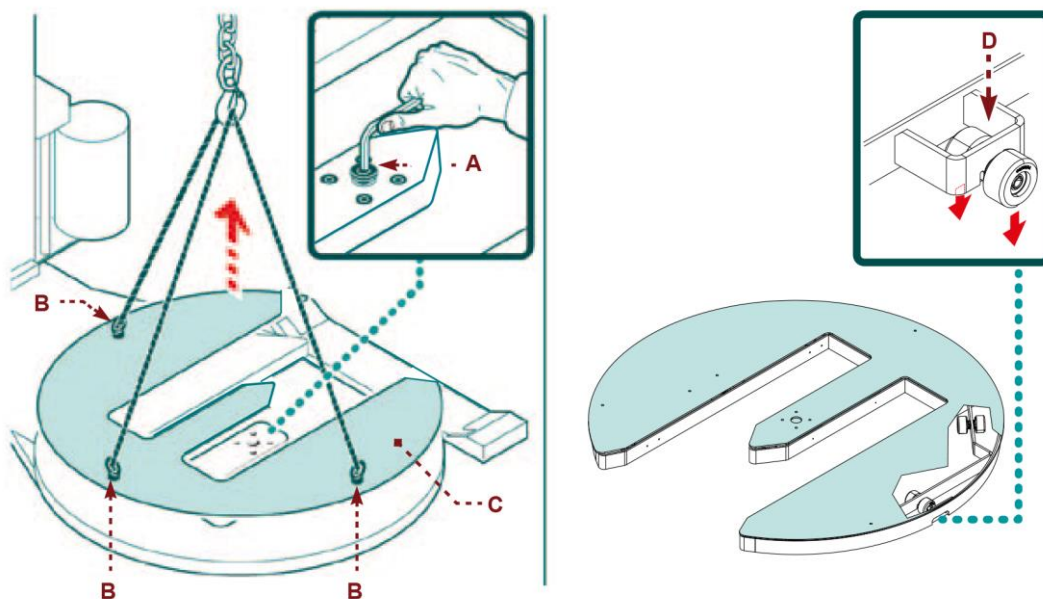

### 9.3. REPLACING THE ROTARY TABLE ROLLERS

1. Loosen the screws (A).
2. Fit the eyebolts (B) on the rotary table (C).
3. Lift the table and place it on the ground.
4. Replace the rollers (D).
5. Reposition the table on the base and fasten it with the screws.



**Important**

Should it not be possible to lift the rotary table using the eyebolts as indicated in point 2, position the support (E) and screw it into the rotary table central seat using the screws (F).  
Lift the rotary table using the fork lifting device.

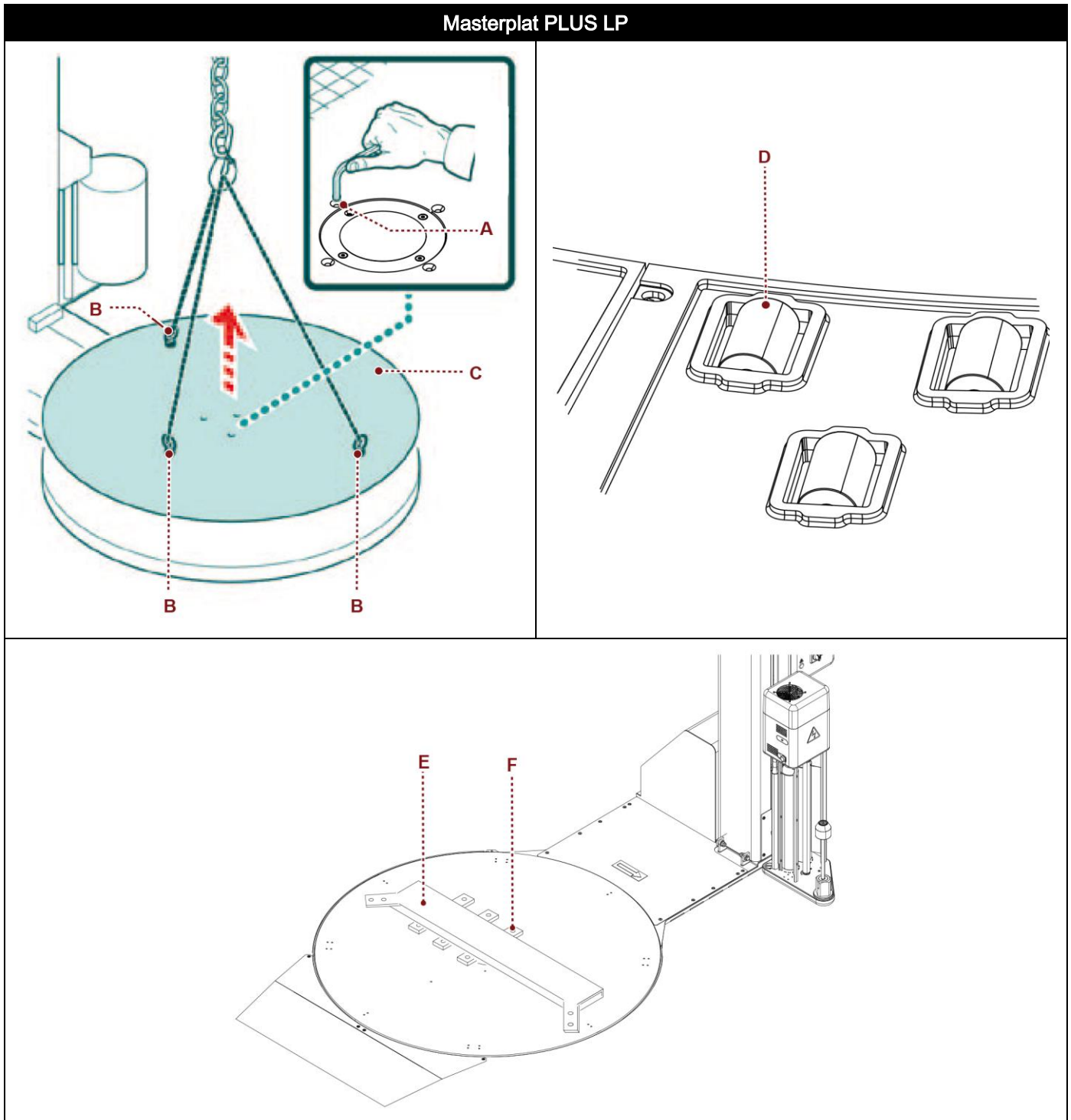

#### 9.4. REPLACING THE GUIDING ROLLERS

1. Loosen the screws (A).
2. Fit the eyebolts (B) on the rotary table (C).
3. Lift the table and place it on the ground.
4. Remove the snap ring (D).
5. Replace the rollers (G).
6. Reposition the table on the base and fasten it with the screws.



**Important**

Should it not be possible to lift the rotary table using the eyebolts as indicated in point 2, position the support (E) and screw it into the rotary table central seat using the screws (F).  
Lift the rotary table using the fork lifting device.

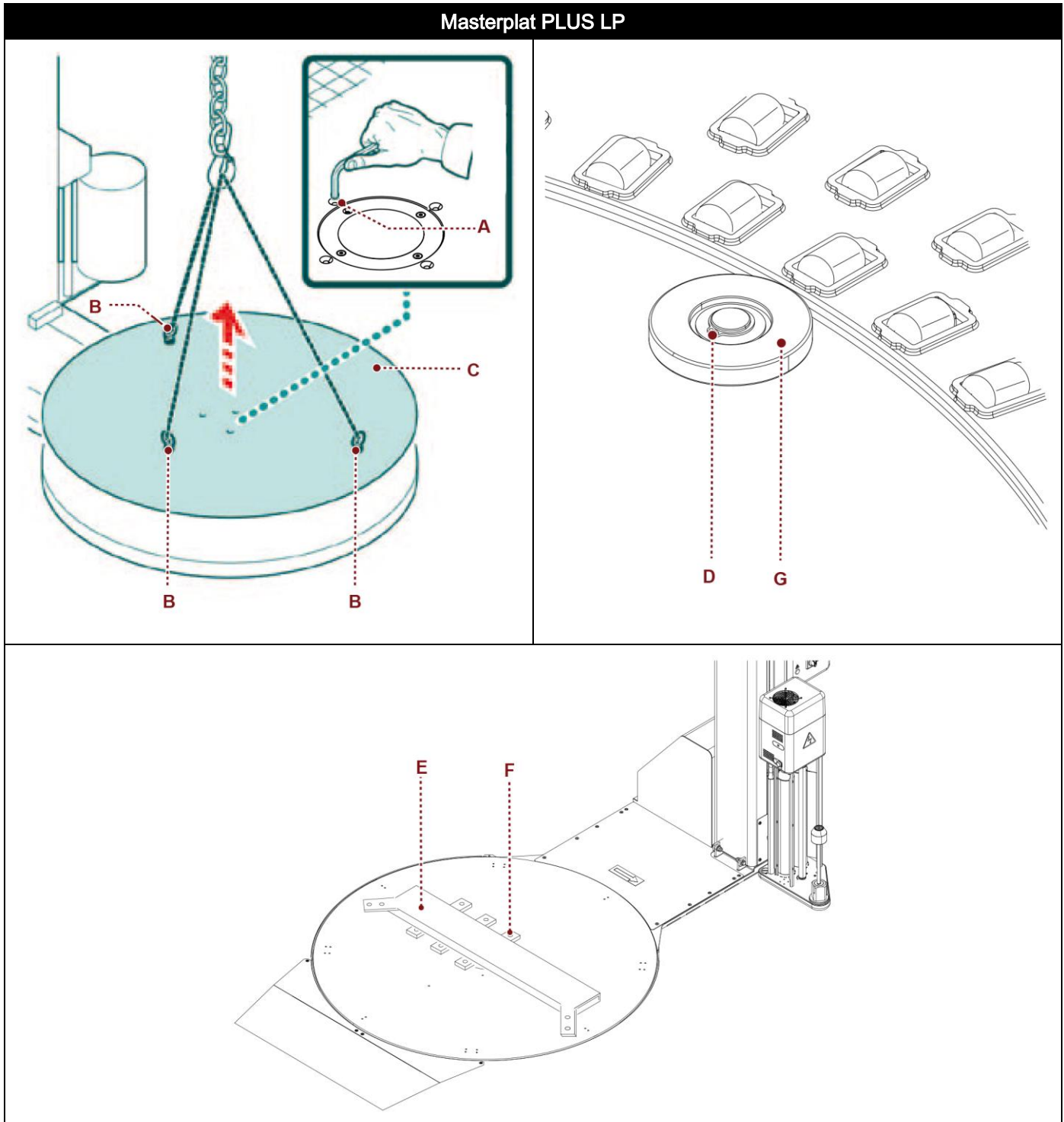

## 9.5. REPLACING THE ROTARY TABLE GEAR WHEELS

1. Remove the cover (A).
2. Loosen the fastening screws (D) of the gear wheels (B) and (C).
3. Replace the gear wheels.



### Danger - warning

Any maintenance operation in this area must be carried out with machine stopped, with electric switch set to OFF and with no other operator near the machine.

### Masterplat PLUS LP

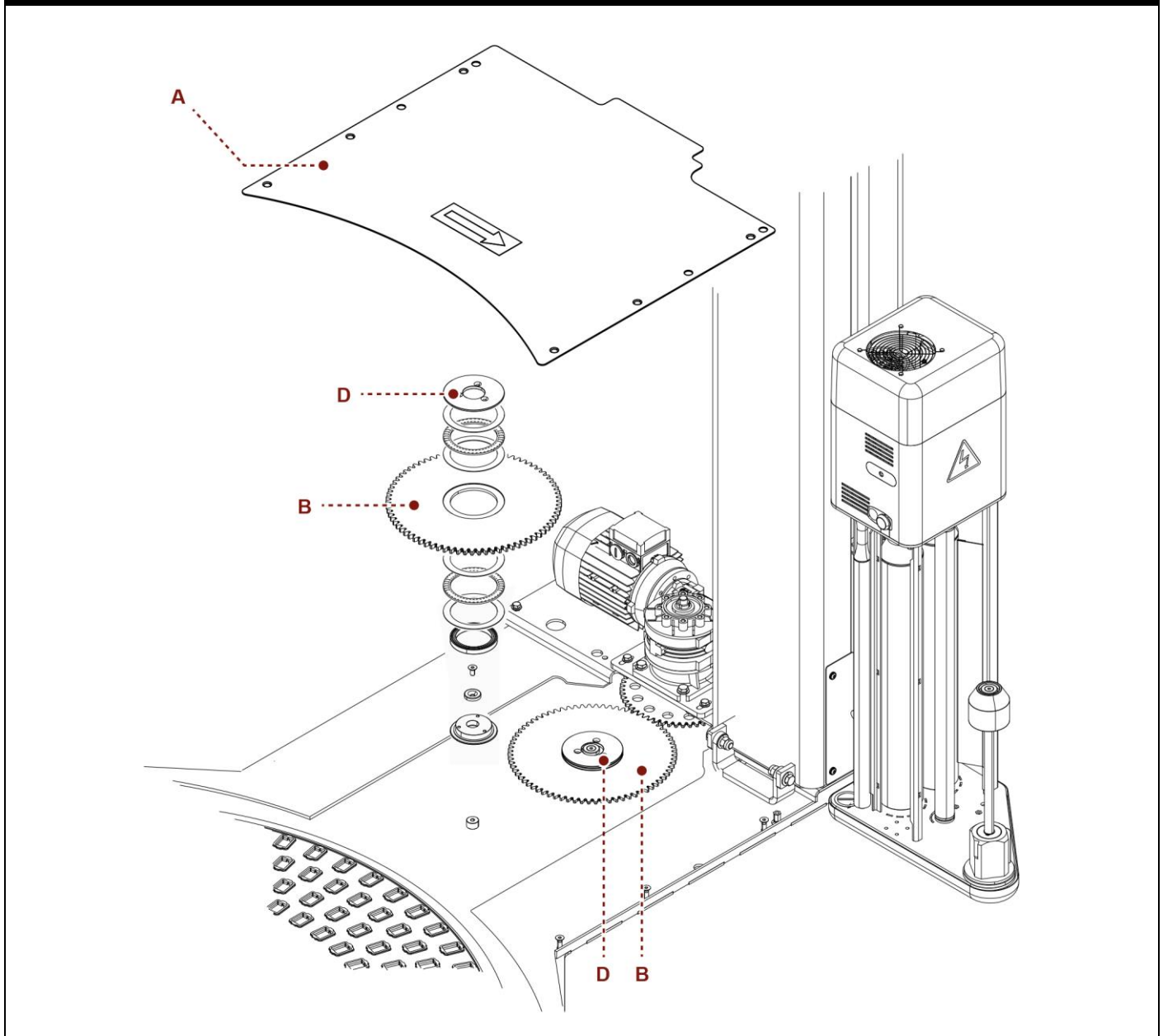

## 9.6. RECOMMENDED SPARE PARTS LIST

List of the spare parts that wear easily and that should be always available to avoid long machine downtimes:

- No. **14** double wheels for base.
- No. **8** carriage supporting wheels.
- No. **1** braked roller pad (Only for spool carriages of "**FRD**" type).
- No. **1** driving belt (Only for spool carriages of "**PGS**" type).

To order them, contact your local dealer and refer to the spare parts catalogue.



### **Important**

Replace worn parts with original spare parts.

Use oils and greases recommended by the Manufacturer.

All the above will ensure the proper operation of the machine and the correct level of safety.

## **9.7. MACHINE DECOMMISSIONING AND SCRAPPING**

### **9.7.1. MACHINE DECOMMISSIONING**

- Cut off any supply to the machine (power, pneumatic, etc.) so that it cannot be restarted and position it in a place that cannot be easily accessed.
- Empty the systems, which contain hazardous substances, in a proper manner and in compliance with the laws in force at workplaces and with those on environmental protection.

### **9.7.2. MACHINE SCRAPPING**

- Scrapping must be performed by authorised centres with experienced personnel and by using the appropriate equipment for safe operating conditions.
- The person who performs the scrapping must identify any possible residual energies and implement a “safety plan” to eliminate unexpected risks.
- The components must be selected according to the chemical and physical features of the material and disposed of separately, in accordance with the applicable laws.
- Empty the systems, which contain hazardous substances, in a proper manner and in compliance with the laws in force at workplaces and with those on environmental protection.



## 10. ANNEXES

### 10.1. WARRANTY CONDITIONS

**Robopac S.p.A.** commits, within the limits described herein, to replace or repair, free of charge, the parts that are defective during the 12 (twelve) months following the date indicated on the company's shipping documents.

To utilise the warranty, the user must immediately notify the company of the detected fault, always referring to the machine serial number.

**Robopac S.p.A.**, in its final judgement, will decide whether to replace the defective part or request it to be shipped for tests and/or repair.

By replacing or repairing the defective part, **Robopac S.p.A.** fully complies with its warranty obligations and will be released from all liabilities and obligations relative to transport, travel and lodge expenses for technicians and installers.

**Robopac S.p.A.** will in no case be held responsible for any losses due to lack of production or injuries to persons or damage to things caused by malfunctions or forced downtime of the machine covered by the warranty.

#### THE WARRANTY DOES NOT COVER:

- Transport failures.
- Damage due to incorrect installation.
- Improper use of the machine or negligence.
- Tampering with or repairs by unauthorised personnel.
- Lack of maintenance.
- Parts subject to normal wear and tear.

For purchased components and parts, **Robopac S.p.A.** offers the user the same warranty conditions that the company obtains from the suppliers of the aforementioned components and/or parts.

**Robopac S.p.A.** does not guarantee the conformity of machines to current standards in countries that are not part of the European Union.

Any adjustment to the regulations in force in the Country in which the machine is installed, will fall under the full responsibility of the user, who will be responsible also for the changes made, releasing **Robopac S.p.A.** from any obligation and/or liability relative to any claim that may be submitted by third parties due to non-compliance with the referenced standards.

## 10.2.PRESSER PNEUMATIC DIAGRAM

### Legend:

- A. Filter/regulator unit
- B. Solenoid valve
- C. Flow regulator
- D. Silencer
- E. Unloading regulator
- F. Presser actuating pneumatic cylinder

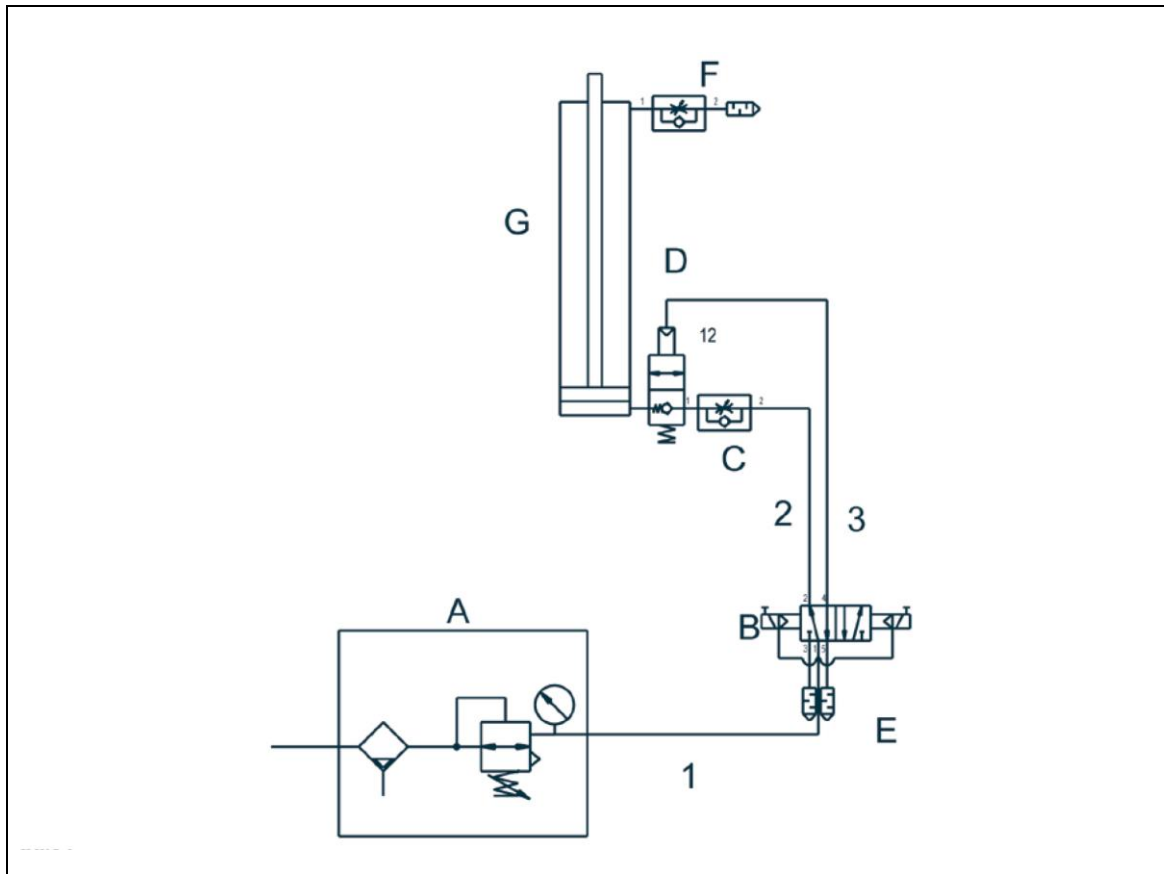

# EC DECLARATION OF CONFORMITY

(Annex IIA DIR. 2006/42/EC)

**Robopac S.p.A.**

Via Fabrizio da Montebello, 81 - 47892

Gualdicciolo Republic of San Marino

## DECLARES THAT THE MACHINE

		
<b>ROBOPAC MACHINERY</b> Robopac S.p.A. Via Fabrizio da Montebello, 81 47892 – Gualdicciolo Repubblica di San Marino <a href="http://www.robopac.com/">http://www.robopac.com/</a>		
		
DENOMINAZIONE DENOMINATION		
MODELLO MODEL		
MATRICOLA SERIAL NUMBER		
DATA DATE OF MANUF.		
ALIMENTAZIONE SUPPLY VOL.		[V]
FREQUENZA FREQUENCY		[HZ]
N° FASI PHASE		
ASSORBIMENTO ABSORPTION		[A]
POTENZA TOT. TOTAL POWER		[kW]
CONSUMO ARIA AIR CONSUMPTION		[nl/min]
PRESSIONE MAX MAX PRESSURE		[bar]
PESO WEIGHT		[kg]

## IS IN CONFORMITY WITH DIRECTIVES

DIRECTIVE 2006/42/EC OF THE EUROPEAN PARLIAMENT AND OF THE COUNCIL of 17 May 2006 on machinery, and amending Directive 95/16/EC.

DIRECTIVE 2014/30/EU OF THE EUROPEAN PARLIAMENT AND OF THE COUNCIL of 26 February 2014 on the harmonisation of the laws of the Member States relating to electromagnetic compatibility.

**Reference to harmonised standards and their annexes, at the applicable points:**

EN ISO 12100:2010, EN 60204-1:2006/A1:2009, EN 415-5:2010, EN 415-6:2013, EN 415-10:2014.

## THE PERSON AUTHORISED TO DRAFT THE TECHNICAL BOOKLET IS

Ing. Pierangelo Laghi - R&D Manager

c/o Aetna Group S.p.A.

S. P. Marecchia, 59

47826 Villa Verucchio

Rimini, Italy

Document date and place

Ing. Pierangelo Laghi - R&D Manager

San Marino,

Signature

ROBOPAC MACHINERY  
**Robopac S.p.A.**  
 Via Fabrizio da Montebello, 81  
 47892 Gualdicciolo  
 Repubblica di San Marino

tel. (+378) 0549 910511  
[robopacmachinery@robopac.com](mailto:robopacmachinery@robopac.com)  
[www.robopac.com](http://www.robopac.com)

Decreto Riconoscimento del 05/12/1983  
 Capitale Sociale € 1.000.000 Cod. Op. Ec. 02346